

# EX3600



## HYDRAULIC EXCAVATOR

Model Code : EX3600-6

Engine Gross Power : 1 450 kW (1 944 HP)

Operating Weight : Backhoe : 359 000 kg

Loading Shovel : 362 000 kg

Backhoe Bucket : SAE, PCSA Heaped : 22.0 m<sup>3</sup>

CECE Heaped : 19.2 m<sup>3</sup>

Loading Shovel Bucket : Heaped : 21.0 - 23.0 m<sup>3</sup>



# **Large Sized Production with the Gigantic Excavators from Hitachi.**

**The Hitachi Giants Keep on Progressing.**

**The Buckets Get Bigger...**

**Along with Enhanced Reliability and Durability.**

**Massive Production and Power on Hand.**





Note: Photos in this brochure may include optional equipment.  
They may also include custom-made options to meet specific user needs.



# Giant-Sized Productivity Based on Hitachi's Theory of Evolution.

Each Hitachi generation listens to the needs of the work site and gives birth to an even-better new generation.

## Bucket Passes to Dump Trucks

Dump Truck	EH3500AC-3
Nominal Payload	181 tonnes
Backhoe 22.0 m <sup>3</sup>	5
Loading Shovel 21.0 m <sup>3</sup>	5

## Powerful Single Engine— Ready for the task.

Time-proven Cummins diesel engine produces a total of 1 450 kW (1 944 HP) for handling the big excavation jobs.

- Engine Rated Power**
- 1 450 kW (1 944 HP)

## Emission Control Engine— Helping to protect our environment.

Conforms to U.S. EPA Tier II emission regulations.

## Efficient E-P Control— Adjusts power output to the work being performed.

Hitachi's computer-aided Engine-Pump Control (E-P Control) coaxes optimum efficiency from the engine and hydraulic pumps. This innovative system senses load demand and controls engine and pump output for maximum operating efficiency.

## Larger Bucket Provides High Work Capacity.

- Backhoe bucket : 22.0 m<sup>3</sup>
- Loading shovel bucket : 21.0 m<sup>3</sup>



## Maximum Excavating Force.

### Backhoe

- Arm crowd force
  - ISO : 951 kN (97 000 kgf)
  - SAE,PCSA : 922 kN (94 000 kgf)
- Bucket digging force
  - ISO : 1 050 kN (107 000 kgf)
  - SAE,PCSA : 932 kN (95 000 kgf)

### Loading shovel

- Arm crowding force on ground : 1 108 kN (113 000 kgf)
- Bucket digging force : 1 166 kN (119 000 kgf)





### Large Bucket— Designed to enhance efficiency.

The large bucket has been shaped specifically to enhance scooping and loading operations. Its sharp tilt angle helps boost operating efficiency.

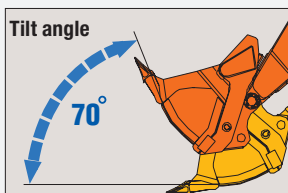

### Productivity-Boosting Auto-Leveling Mechanism— One-lever leveling control.

This is another unique Hitachi function developed exclusively for more efficient leveling operations.



# More Than Durable— Just Plain Tough

Built-in toughness means the Hitachi will continue to get giant-sized jobs done fast.

## Rigid Box Design— Resists bending and twisting forces.

Computer-assisted analysis was used to check that the frame box can withstand heavy-duty excavation work.

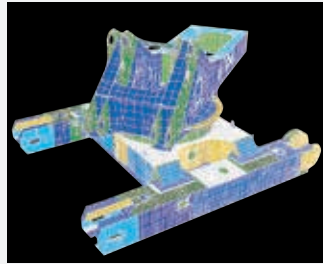

## Center Track Frame— More strength for this key area.

The center track frame of integral cast steel structure can avoid stress concentration and increase reliability.



## Strategically Positioned Oil Coolers— Help to keep oil temperatures.

Four oil coolers are used for optimal cooling efficiency. They are positioned far from the engine radiator for even better cooling potential.



## High-Mounted Compact Travel Motors and Optional Travel Motor Guard— Help to boost durability at rugged work sites.

This design helps protect the travel motors from damage by rocks.







**Rugged Track Links—  
Shoes include roller guides for extended service life.**

This design has proven itself on Hitachi's popular Giant EX Series. The roller guides have been added to help extend service life.

**Roller guide**

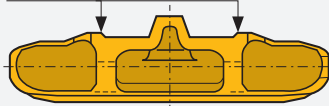

**Constant Correct Track Tension—  
Nitrogen gas accumulators absorb abnormal track tension.**

Helps prevent abnormal track tension from causing damage. Travel is automatically stopped if accumulator pressure exceeds a preset level.





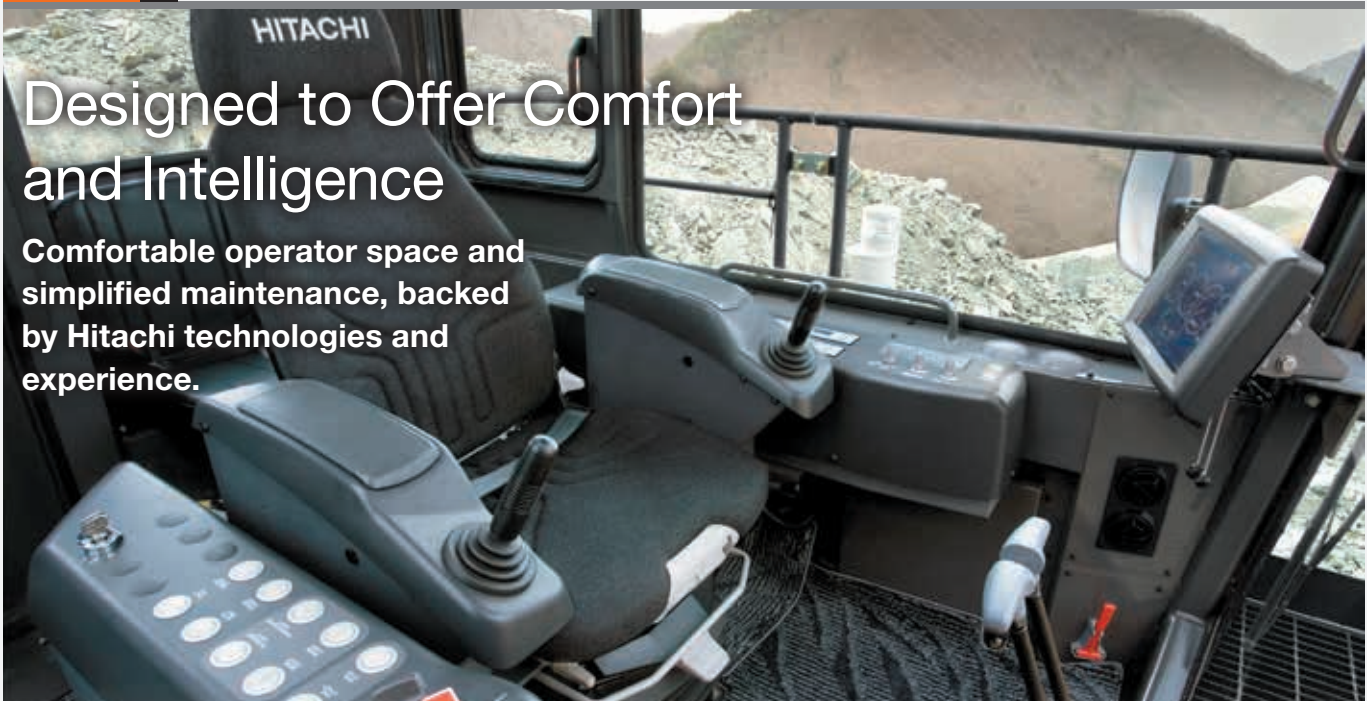

# Designed to Offer Comfort and Intelligence

**Comfortable operator space and simplified maintenance, backed by Hitachi technologies and experience.**

## High Visibility 6.83 Meter Cab Height— Providing a clear view of the work area.

Gives the operator a clear view, even when a large 190 tonnes class dump truck is being loaded. This high height and forward-sloping cab provides a view that boosts productivity.

## Rugged Comfortable Cab— Protects the operator from falling objects.

Fluid-filled elastic mounts help absorb vibration to provide durability and a comfortable ride. The OPG\* top guard level II (ISO) is provided on the cab roof.

\*Operator Protective Guard

## Efficient Cab Layout— All controls within natural reach of operator.

The ergonomic layout of the cab means the operator will do less stretching and reaching when operating the controls. This adds up to less operator fatigue and greater operating efficiency.

## Electric Joystick Levers— Provides pleasant control with less fatigue.

Electric joystick control levers have a feather-touch allowing long periods of effortless operation. Its stroke is much shorter than that of hydraulic control.

## Air Suspension Seat with Auto Operator Weight Adjuster.

The operator seat cushion can automatically be adjusted according to the operator weight. This is convenient for a machine operated by two or more operators.

## Adjustable Sliding Cockpit— Moves to the best position for the operator.

The operator can adjust the position of the levers and the seat to custom fit his size and operating style.

## Constant-Cab-Comfort Air Conditioner— Keeps the cab pressurized to keep out dust while maintaining comfortable temperature.

## Intelligent Multi-Display Monitor— Provides machine data and operating status at a glance.

The operator can monitor machine conditions and operating status with a 10.5-inch color LCD. The controller provides instant fault diagnosis through all sensors, displaying warnings and countermeasures if failure arises.



\* Illustration shows a sample of the Emergency Switch.

## Outside Cameras (Optional)— Enhances operating safety.

The operator can monitor around the machine, using four optional cameras to eliminate blind spots.

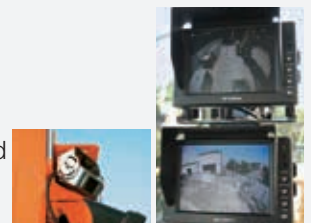



# AerialAngle (Optional)

## Hitachi Hydraulic Excavator with Peripheral Vision Support System



### Camera Monitor

A camera monitor for AerialAngle is located on the left-front pillar of the cab. A screen changeover switch is located on the right hand side of the monitor.



### Locations of the Cameras & Viewing Angles

The AerialAngle feature is available to significantly increase peripheral vision around the hydraulic excavator by providing synthesized multiple images captured by cameras specifically positioned at 4 locations around the excavator.

The feature displays camera views on a single monitor to allow operators an auxiliary means of checking for ground level obstacles.

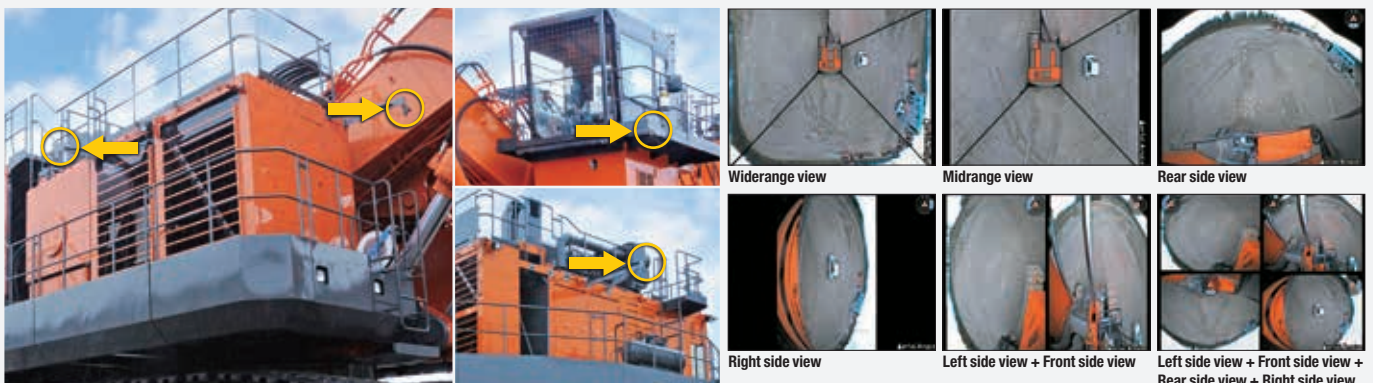

\* 4 on-board cameras on the EX3600-6

Aerial Angle is an auxiliary safety system and its use should never substitute for the use of common-sense safety measures, direct visual observation, and professional judgment. Never rely solely upon Aerial Angle to assess the surrounding environment. When operating the machine, be sure to check directly all around the machine with your eyes for safety operating.



# Designed to be Maintainable

Carefully engineered to allow full 24-hour operation.



## Easy Access and Maintenance— Easy access speeds inspections and maintenance.

The wide fender, spacious counterweight top and central passage give easy access to major components for convenience of inspection and maintenance.

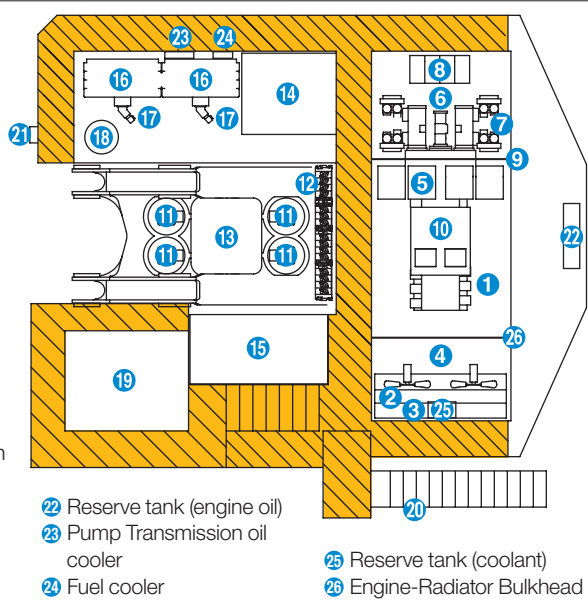

- 1 Engine
- 2 Engine Radiator
- 3 LTA Radiator
- 4 Fan Motor x 4
- 5 Air Filter x 4
- 6 Hydraulic Pump x 8
- 7 High-Pressure Strainer x 8
- 8 Battery Unit
- 9 Engine-Pump Bulkhead
- 10 Muffler
- 11 Swing Device x 4
- 12 Control Valve x 4
- 13 Center Joint
- 14 Hydraulic Oil Tank
- 15 Fuel Tank
- 16 Hydraulic Oil Cooler x 4
- 17 Hydraulic Oil Cooling Fan Motor x 2
- 18 Lubricator
- 19 Cab
- 20 Folding Stairs
- 21 Ladder
- 22 Reserve tank (engine oil)
- 23 Pump Transmission oil cooler
- 24 Fuel cooler
- 25 Reserve tank (coolant)
- 26 Engine-Radiator Bulkhead

## Multipurpose Counterweight— Easier access for maintenance.

A walkway around the entire counterweight provides easy access to key rear areas. This means faster and safer inspection and maintenance.



## Folding Stairs with Wide Steps.

Folding stairs are designed for easy access to the machine for servicing and maintenance.



## Wide-Open Service Area— Provides the space needed for quick and easy inspection and maintenance.

This area is conveniently located at the center of the body and provides access to the engine as well as the hydraulic and electrical systems.



## Auto Lubrication System— Eliminates the need for manual lubrication.

This system automatically lubricates the front joint pins and swing circle. This eliminates cumbersome daily lubrication.

## Easy-to-Replace Grease Drum Can— Designed to provide quick and easy grease drum can changes.

The compartment floor slides down to lower a drum for simple, easy replacement.



## Convenient Centralized Filter System— Designed to make filter inspection and maintenance easier.

Centralized position means that inspection and maintenance can be performed quickly and easily.

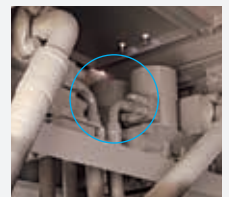

## The Centralized Lubrication System: Fast Filling System







**Low Maintenance Dust Ejector—  
Automatically expels dust from the air cleaner.**

This is one less time-consuming task during routine maintenance.

**Contamination sensor—  
Alerts the operator of excessive contaminants in the oil.**

This system detects accumulated contaminants that could cause damage and alerts the operator before trouble occurs.



**Remote Machine Management with Global e-Service**

This on-line machine management system allows you to access each on-site machine from a PC in your office. You can get its operating information and location to increase productivity. Operating data and log are sent to a Hitachi server for processing, and then to customer and dealers. This system is available 24 hours a day, all the year around.

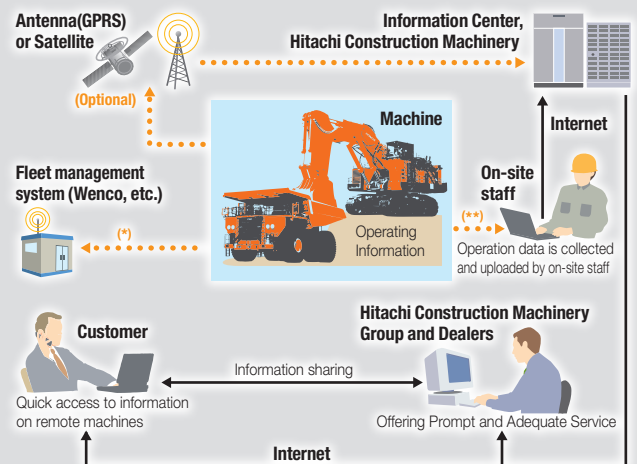

Note : In some regions, Global e-service is not available by local regulations.  
 \* DTU (optional) and fleet management system contract are required.  
 DTU : Data Transfer Unit  
 \*\*WIU (optional) to transmit operating data for wireless collection is required.  
 WIU : Wireless Interface Unit



## WORKING RANGES

Unit: mm

### Backhoe (22.0 m<sup>3</sup> bucket)

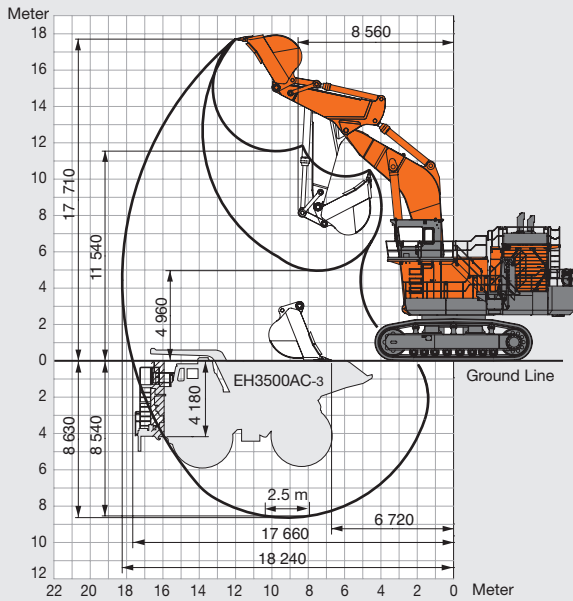

### Loading Shovel (21.0 m<sup>3</sup> bucket)

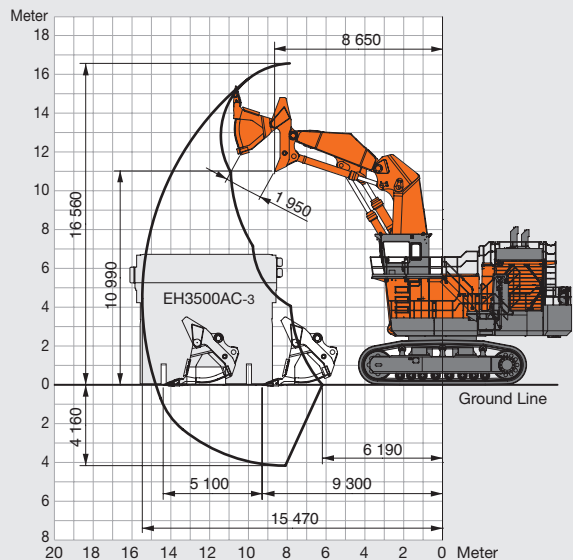

## DIMENSIONS

Unit: mm

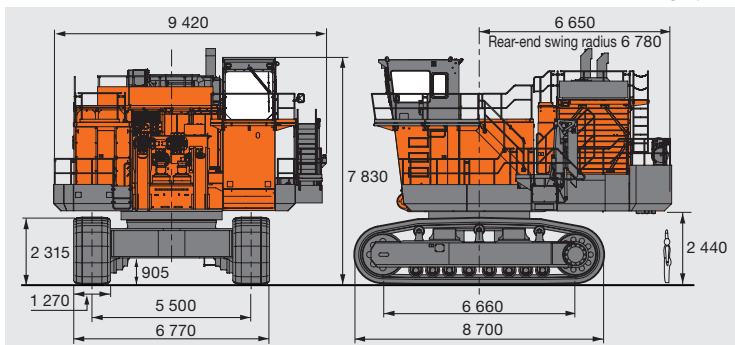

Before using a machine with a satellite communication system, please make sure that the satellite communication system complies with local regulations, safety standards and legal requirements. If not so, please make modifications accordingly.

## ENGINE

Model..... Cummins QSKTA60-CE  
 Rated power  
 SAE J1995, gross ..... 1 450 kW (1 944 HP) at 1 800 min<sup>-1</sup> (rpm)  
 Net..... 1 450 kW (1 944 HP) at 1 800 min<sup>-1</sup> (rpm)  
 Piston displacement ..... 60.0 L  
 Fuel tank capacity ..... 7 450 L

## HYDRAULIC SYSTEM

Main pumps ..... 8 variable-displacement, axial piston pumps for front attachment, travel and swing  
 Pressure setting ..... 29.4 MPa (300 kgf/cm<sup>2</sup>)  
 Max. oil flow ..... 8 x 500 L/min

## DIGGING FORCE

### Backhoe (22.0 m<sup>3</sup> bucket)

Arm crowd force ..... ISO : 951 kN (97 000 kgf)  
 SAE, PCSA : 922 kN (94 000 kgf)  
 Bucket digging force ..... ISO : 1 050 kN (107 000 kgf)  
 SAE, PCSA : 932 kN (95 000 kgf)

### Loading Shovel (21.0 m<sup>3</sup> bucket)

Arm crowding force on ground.. 1 108 kN (113 000 kgf)  
 Bucket digging force ..... 1 166 kN (119 000 kgf)

## UPPERSTRUCTURE

Swing speed ..... 3.2 min<sup>-1</sup> (rpm)

## UNDERCARRIAGE

Travel speeds ..... High: 0 to 2.2 km/h Low : 0 to 1.7 km/h  
 Maximum traction force ..... 1 760 kN (179 500 kgf)  
 Gradeability ..... 58 % (30 degree) max.

## WEIGHTS AND GROUND PRESSURE

### Backhoe

Equipped with 9.6 m BE-boom, 4.5 m BE-arm and 22.0 m<sup>3</sup> (SAE, PCSA heaped) bucket.

Shoe type	Shoe width	Operating weight	Ground pressure
Triple grousers	1 270 mm	359 000 kg	188 kPa (1.92 kgf/cm <sup>2</sup> )

### Loading Shovel

Equipped with 21.0 m<sup>3</sup> (heaped) bottom dump bucket.

Shoe type	Shoe width	Operating weight	Ground pressure
Triple grousers	1 270 mm	362 000 kg	190 kPa (1.94 kgf/cm <sup>2</sup> )

## ATTACHMENTS

### Backhoe: Bucket Capacity (SAE, PCSA heaped)

22.0 m<sup>3</sup> : Materials density 1 800 kg/m<sup>3</sup> or less

### Loading Shovel: Bucket Capacity (heaped)

21.0 m<sup>3</sup> : Materials density 1 800 kg/m<sup>3</sup> or less

23.0 m<sup>3</sup> : Materials density 1 600 kg/m<sup>3</sup> or less

The number of wear plates and their installation positions on the bucket of loading shovel or backhoe vary depending on applications at job site.

The installation of wear plates is indispensable.

Consult your nearest Hitachi or Hitachi dealer for details.

These specifications are subject to change without notice.

Illustrations and photos show the standard models, and may or may not include optional equipment, accessories, and all standard equipment with some differences in color and features.

Before use, read and understand the Operator's Manual for proper operation.