

ZAXIS-7 series

HITACHI

Reliable solutions

ZAXIS250/260LC



HYDRAULIC EXCAVATOR

Model code : ZX250-7

Engine rated power : 140 kW (ISO 14396) /
132 kW (ISO 9249)

Operating weight : 25 900 – 26 500 kg

Bucket ISO heaped : 0.80 – 1.40 m³

Model code : ZX260LC-7

Engine rated power : 140 kW (ISO 14396) /
132 kW (ISO 9249)

Operating weight : 26 700 – 27 300 kg

Bucket ISO heaped : 0.80 – 1.40 m³



YOU'RE IN CONTROL

You're at the heart of Hitachi's design for its latest range of excavators. To continuously improve on previous generation machines we've focused on enhancing your experience in the cab as an operator.

We've considered the challenges you face as the owner of a successful business. And we've zoomed in on the ways in which we can support you over the life cycle of your machine.

By putting you at the heart of the Zaxis-7 range, we invite you to take control – over your workspace and your fleet. And by working in partnership, we will help you to create your vision.



INSIDE



4. Complete Control
In control of your assets

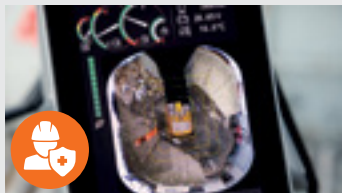

6. Increase your safety
Be in control of your environment



8. Boost your uptime
Improve your profit



11. Control Zone
Feel the difference

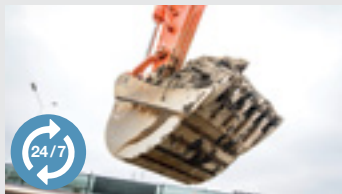

12. Get More from your machine
In control of your performance



14. Specifications
Know your machine



COMPLETE CONTROL

The new Zaxis-7 range of medium excavators puts you firmly in control, so you can feel assured of your machine's performance and supported by the technological expertise and services that Hitachi provides.



The expanded cab interior provides a more comfortable working environment.



Integrated console and seat suspension gives a greater sense of control, and helps to reduce fatigue.



Visibility of the job site is excellent thanks to the Aerial Angle® camera system and new LCD monitor.



Sensors monitor oil continuously and contribute to preventative maintenance, helping to reduce downtime.



ConSite Pocket app allows you to manage and monitor your fleet remotely.



Options such as Hitachi ground engaging tools enable you to enhance the performance of your excavator.



Improved access to components ensures maintenance is quick and easy.



The improved TRIAS III hydraulic system reduces fuel consumption and increases efficiency.



The ECO gauge on the monitor indicates how to lower fuel consumption and reduce costs.



INCREASE YOUR SAFETY

Your ability to work safely is vital, not only for your own wellbeing, but also for the successful completion of any project. To protect yourself and your machine from potential hazards, the new Hitachi Zaxis-7 excavators give you a superior view of your surroundings, so you can see the job site from all angles.

The visibility you enjoy from the cab includes an exceptional 270-degree bird's-eye view with the Aerial Angle® camera system. You can choose from six image options to view the machine's immediate environment, which enables you to control your own safety – as well as that of those around you.

To help you to work more confidently and efficiently, even in the most challenging of conditions, Zaxis-7 excavators are fitted with some impressive new features. From the LED work lights and the windscreen wiper with an increased sweeping area, to the large reflective strips on the counterweight and roller sunshades, you'll have the visibility you need when it matters most.

Attention to detail is also fundamental to a safe working environment – and the repositioning of the pilot shutoff lever is a perfect example. It is now within easy reach to prevent any unintentional actions.



The pilot shutoff lever offers enhanced safety in the cab.



Choose between different image layouts to suit your working environment.



LED work lights improve visibility in challenging conditions.

BOOST YOUR UPTIME

Completing a project on time and on budget depends on the ability of your construction equipment to perform all day, every day. That's why Hitachi owners have profited from generations of ultra-reliable and durable machinery – and the Zaxis-7 range is no exception.

The latest Hitachi medium excavators have been built to last, so that you can remain in complete control of your assets. They have been tested rigorously and continuously at dedicated facilities in Japan with the goal of significantly boosting your uptime.

As a result, a wide range of durable new components have been fitted to the latest Stage-V compliant machines – even down to the detail of the rigidity of the door hinges. Now standard on our Zaxis-7 range are hydraulic and engine oil monitoring sensors that help to reduce downtime and running costs.

Downtime is prevented by the durable after-treatment system, and also minimised by the priority given to easy maintenance and cleaning – saving you time and money. Peace of mind comes from such features as the two-way disconnect switch. This makes it possible to shut down power without resetting data on the monitor and prevents the battery from discharging during welding.

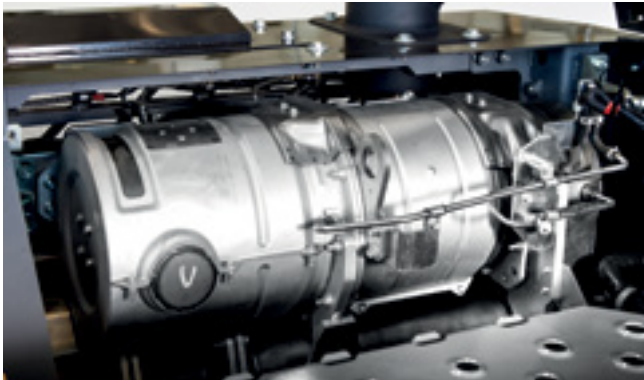

Durable after-treatment system prevents downtime.



Strong X-beam, undercarriage and under covers enhance durability.

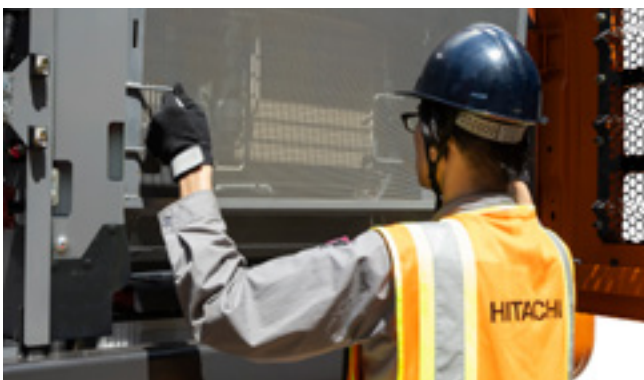

Maintenance is easy at ground level.

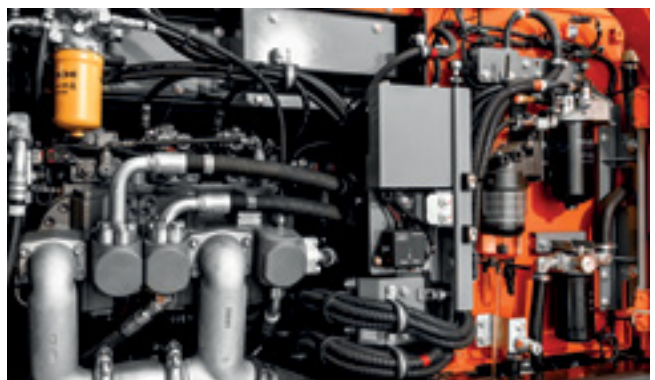

New layout provides convenient access to all filters.



Designed for durability and easy maintenance, Zaxis-7 excavators increase uptime and reduce the total cost of ownership.



1

2

4

3

16

5

15

13

14

6

7

8

9

11

12

10

CONTROL ZONE

Enhanced comfort and safety features are at your fingertips in the refined cab of Zaxis-7 excavators, giving you the power to perform productively, with ease and reduced fatigue.

- 1 **Increased sweeping area of wide view wiper** enhances visibility in difficult working conditions. *(Option only)
- 2 **Air conditioning and audio** are easily controlled via the monitor.
- 3 **Low-reflective colour 8" LCD monitor** is easy to view and navigate.
- 4 **USB power supply and smartphone holder** helps you stay connected.
- 5 **Drinks holder** is easy to detach for cleaning.
- 6 **Additional joystick controls** for effortless operation.
- 7 **Ergonomic design** gives you convenient access to controls.
- 8 **Bluetooth®** for hands-free calls and **DAB+** radio for music while you work.
- 9 **Multifunctional control panel** makes operation easier.
- 10 **Improved sound isolation** makes this one of the quietest cabs in the market.
- 11 **User-friendly storage space** keeps your workspace tidy and clutter-free.
- 12 **12v and 24v outlets** for your electrical devices.
- 13 **One-touch adjustment lever for console** so you can work comfortably in the optimum position.
- 14 **Integrated console and seat suspension** gives a greater sense of control and helps to reduce fatigue.
- 15 **Increased legroom** creates a more spacious cab.
- 16 **Optimal pedal layout** helps to reduce fatigue.



Operation is easy with ergonomically designed controls and switches.



Bluetooth® connection for hands-free calls while you work.

GET MORE FROM YOUR MACHINE

Designed to work in perfect harmony with your machine, Hitachi preferred durable hydraulic breakers, hydraulic hitches, buckets and Ground Engaging Tools (GET) will increase your profit by maximising productivity and uptime. Manufactured to the same high standards as all Hitachi construction equipment, they offer unrivalled reliability and exceptional performance.

Buckets

You can increase the versatility of your excavator by choosing the right bucket for the job. For loading light materials or heavy-duty work, Hitachi buckets can be customised to meet your needs. You have a wide range of options to choose from Hitachi supplied buckets with different capacities and widths.

Ground engaging tools

You can enhance the digging power and productivity of your excavator or wheel loader with Hitachi GET. Quick and safe to install and replace, they fit precisely to your attachments and can be tailored to suit the task. Using Hitachi GET can reduce your maintenance costs and downtime, lower fuel consumption and enhance the overall performance of your machine.

Breakers

High-performance hydraulic breakers – approved by Hitachi – are perfectly suited to medium excavators. They are easy to maintain and user-friendly, and their high-quality materials ensure a long lifetime. This means reduced maintenance costs, fewer replacement parts and minimal downtime.



Attachments can be customised to suit the application.



Breakers are lightweight with high impact energy.



Hitachi GET include teeth and reliable adapters to ensure a precise fit.
*Not available in all markets



High performance hydraulic quick hitches approved by Hitachi.



250

HITACHI

SPECIFICATIONS

ENGINE	
Model	Isuzu 4HK1X
Type	4-cycle water-cooled, common rail direct injection
Aspiration	Variable geometry turbocharged, intercooled, cooled EGR
Aftertreatment	DOC+CSF+SCR system
No. of cylinders	4
Rated power	
ISO 14396 : 2002 gross	140 kW at 2 000 min ⁻¹
ISO 9249 : 2007 net	132 kW at 2 000 min ⁻¹
SAE J1349 : net	132 kW at 2 000 min ⁻¹
Maximum torque	676 Nm at 1 800 min ⁻¹
Piston displacement	5.193 L
Bore and stroke	115 mm x 125 mm
Batteries	2 x 12 V / 126 Ah

HYDRAULIC SYSTEM			
Hydraulic Pumps			
Main pumps	3 variable displacement axial piston pumps		
Maximum oil flow	2 x 224 L/min		
	1 x 194 L/min		
Pilot pump	1 gear pump		
Maximum oil flow	35.5 L/min		
Hydraulic Motors			
Travel	2 variable displacement axial piston motors		
Swing	1 axial piston motor		
Relief Valve Settings			
Implement circuit	34.3 MPa		
Swing circuit	32.4 MPa		
Travel circuit	34.3 MPa		
Pilot circuit	3.9 MPa		
Power boost	38.0 MPa		
Hydraulic Cylinders			
	Quantity	Bore	Rod diameter
Boom	2	125 mm	90 mm
Arm	1	140 mm	100 mm
Bucket	1	130 mm	90 mm

UPPERSTRUCTURE	
Revolving Frame	
D-section frame for resistance to deformation.	
Swing Device	
Axial piston motor with planetary reduction gear is bathed in oil. Swing circle is single-row. Swing parking brake is spring-set/hydraulic-released disc type.	
Swing speed	10.7 min ⁻¹
Swing torque	77.5 kNm

UNDERCARRIAGE		
Tracks		
Tractor-type undercarriage. Welded track frame using selected materials.		
Side frame welded to track frame. Lubricated track rollers, idlers, and sprockets with floating seals.		
Track shoes with triple grousers made of induction-hardened rolled alloy.		
Heat-treated connecting pins with dirt seals. Hydraulic (grease) track adjusters with shock-absorbing recoil springs.		
Numbers of Rollers and Shoes on Each Side		
	ZX250-7	ZX260LC-7
Upper rollers	2	2
Lower rollers	8	9
Track shoes	47	51
Track guards	3	3
Travel Device		
Each track driven by 2-speed axial piston motor.		
Parking brake is spring-set/hydraulic-released disc type.		
Automatic transmission system: High-Low.		
Travel speeds	High : 0 to 5.5 km/h	
	Low : 0 to 3.4 km/h	
Maximum traction force	215 kN	
Gradeability	70% (35 degree) continuous	

SERVICE REFILL CAPACITIES	
Fuel tank	510.0 L
Engine coolant	31.0 L
Engine oil	29.0 L
Swing device	9.3 L
Travel device (each side)	7.8 L
Hydraulic system	294.0 L
Hydraulic oil tank	156.0 L
DEF/AdBlue® tank	70.0 L

ENVIRONMENT	
Engine Emissions	EU Stage V
Sounds Level	
Sound level in cab according to ISO 6396 : 2008	67 LpA dB(A)
External sound level according to ISO 6395 : 2008 and EU Directive 2000/14/EC	102 LwA dB(A)
Air Conditioning System	
The air conditioning system contains fluorinated greenhouse gases. Refrigerant type: HFC-134a, GWP: 1430, Amount: 0.85kg, CO2e: 1.22ton.	

WEIGHTS AND GROUND PRESSURE

Operating Weight and Ground Pressure

			ZX250-7 *1		ZX260LC-7 *1	
Boom type			Monoblock		Monoblock	
Shoe type	Shoe width (mm)	Arm length (m)	kg	kPa	kg	kPa
Triple grouser	600 mm	2.50	25 900	58.8	26 700	52.9
		2.96	26 000	58.9	26 700	53.0
	700 mm	2.50	26 200	51.0	27 000	45.9
		2.96	26 300	51.0	27 100	46.0
	800 mm	2.50	26 500	45.0	27 300	40.6
		2.96	26 500	45.1	27 300	40.7

*1 Including 1.00 m³ (ISO heaped) bucket weight (850 kg) and counterweight (6 200 kg).

BASIC MACHINE WEIGHT AND COMPONENTS WEIGHT

Basic Machine Weight and Overall Width

Excluding front end attachment, fuel, hydraulic oil and coolant etc. Including counterweight (6 200 kg).

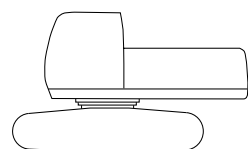

		ZX250-7		ZX260LC-7	
Shoe type	Shoe width (mm)	Weight (kg)	Overall width (mm)	Weight (kg)	Overall width (mm)
Triple grouser	600	20 000	2 900	20 800	3 190
	700	20 300	3 090	21 100	3 290
	800	20 600	3 190	21 400	3 390

Components Weight

Unit: kg

	ZX250-7 & ZX260LC-7
Counterweight	6 200
Monoblock boom (with arm cylinder and boom cylinder)	2 840
Arm 2.50 m (with bucket cylinder)	1 380
Arm 2.96 m (with bucket cylinder)	1 420

BUCKET AND ARM DIGGING FORCE

Unit: kN

	ZX250-7 & ZX260LC-7	
Arm length	2.50 m	2.96 m
Bucket digging force* ISO 6015 : 2006	188 kN	188 kN
Arm crowd force* ISO 6015 : 2006	156 kN	131 kN

* At power boost

SPECIFICATIONS

WORKING RANGES

MONOBLOCK BOOM

meter

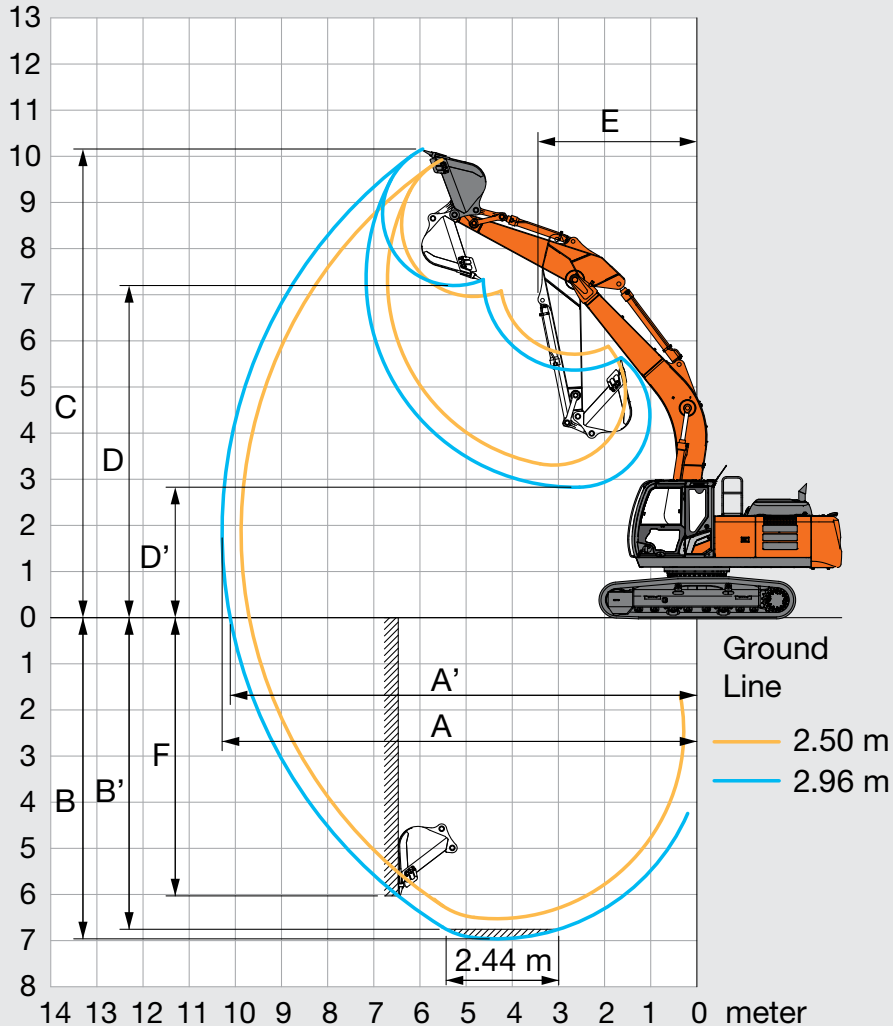

Unit: mm

Arm length	Monoblock boom	
	2.50 m	2.96 m
A Max. digging reach	9 880	10 290
A' Max. digging reach (on ground)	9 690	10 110
B Max. digging depth	6 500	6 960
B' Max. digging depth for 2.44 m level	6 270	6 750
C Max. cutting height	9 950	10 160
D Max. dumping height	6 990	7 200
D' Min. dumping height	3 330	2 830
E Min. swing radius	3 480	3 440
F Max. vertical wall digging depth	5 580	6 030

Excluding track shoe lug

DIMENSIONS

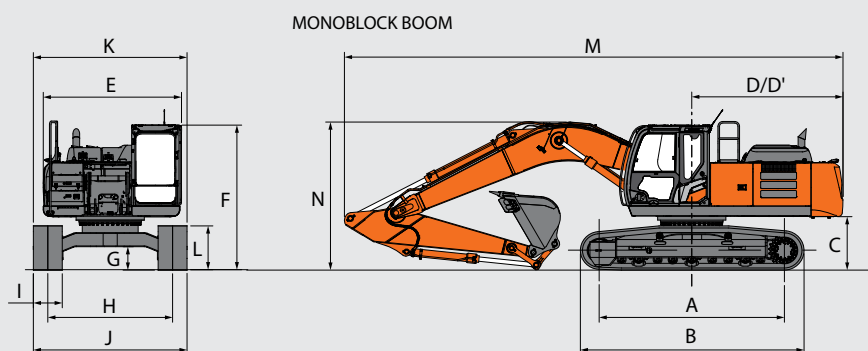

Unit: mm

	ZX250-7	ZX260LC-7
	Monoblock boom	
A Distance between tumbler	3 460	3 850
B Undercarriage length	4 260	4 640
*C Counterweight clearance	1 050	1 050
D Rear-end swing radius	3 140	3 140
D' Rear-end length	3 140	3 140
E Overall width of upperstructure	2 870	2 870
F Overall height of cab	3 190	3 190
*G Min. ground clearance	460	460
H Track gauge	2 390	2 590
I Track shoe width	600	600
J Undercarriage width	2 990	3 190
K Overall width	2 990	3 190
L Track height	920	920
M Overall length		
With Arm 2.5 m	10 470	10 470
With Arm 2.96 m	10 350	10 350
N Overall height of boom		
With Arm 2.5 m	3 390	3 390
With Arm 2.96 m	3 110	3 110

*C,G,L: Excluding track shoe lug G:Triple Grouser shoe

MACHINE CAPACITIES

- Notes: 1. Ratings are based on ISO 10567 : 2007.
 2. Machine capacity does not exceed 75% of tipping load with the machine on firm, level ground or 87% full hydraulic capacity.
 3. The load point is the center line of the bucket pivot mounting pin on the arm.
 4. *Indicates load limited by hydraulic capacity.
 5. 0 m = Ground.

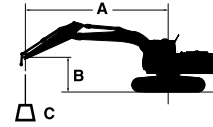

- A: Load radius
 B: Load point height
 C: Machine capacity

For machine capacities, subtract installed attachment and quick hitch weight from machine capacities.

To determine lifting capacities, apply "Rating over side or 360 degrees" machine capacities from the table and deduct weight of installed attachment and quick hitch. Optional feature may affect machine performance.

ZX250-7 MONOBLOCK BOOM

Rating over-front Rating over-side or 360 degrees Unit : kg

Conditions	Load point height m	Load radius										At max. reach		
		1.5 m		3.0 m		4.5 m		6.0 m		7.5 m		meter		
Boom 6.0 m Arm 2.5 m Counterweight 6 200 kg	6.0							*6 220	*6 220			*6 170	5 230	7.20
	4.5					*8 410	*8 410	*6 940	6 790	*6 310	4 810	*6 200	4 440	7.88
	3.0					*10 740	9 670	*7 970	6 440	6 590	4 660	5 710	4 040	8.24
	1.5					*12 500	9 080	8 900	6 130	6 430	4 510	5 540	3 900	8.31
	0 (Ground)					*13 080	8 850	8 690	5 950	6 310	4 410	5 680	3 980	8.10
	-1.5			*9 490	*9 490	*12 780	8 840	8 620	5 890	6 300	4 390	6 210	4 340	7.58
	-3.0			*15 900	*15 900	*11 670	8 970	8 720	5 970			7 490	5 190	6.69
	-4.5			*12 410	*12 410	*9 180	*9 180					*7 690	7 530	5.23
Boom 6.0 m Arm 2.96 m Counterweight 6 200 kg	6.0							*5 700	*5 700	*4 880	*4 880	*4 330	*4 330	7.67
	4.5					*7 640	*7 640	*6 470	*6 470	*5 930	4 870	*4 350	4 110	8.32
	3.0					*9 990	9 890	*7 560	6 530	*6 440	4 700	*4 530	3 760	8.65
	1.5					*12 000	9 210	*8 630	6 190	6 450	4 530	*4 910	3 640	8.72
	0 (Ground)					*12 950	8 880	8 710	5 960	6 310	4 400	5 270	3 700	8.52
	-1.5			*9 330	*9 330	*12 950	8 810	8 600	5 870	6 250	4 350	5 700	3 980	8.03
	-3.0	*10 830	*10 830	*15 510	*15 510	*12 140	8 890	8 640	5 900			6 690	4 650	7.20
	-4.5			*14 040	*14 040	*10 180	9 150					*7 500	6 310	5.87

ZX260LC-7 MONOBLOCK BOOM

Rating over-front Rating over-side or 360 degrees Unit : kg

Conditions	Load point height m	Load radius										At max. reach		
		1.5 m		3.0 m		4.5 m		6.0 m		7.5 m		meter		
Boom 6.0 m Arm 2.5 m Counterweight 6 200 kg	6.0							*6 220	*6 220			*6 170	5 780	7.20
	4.5					*8 410	*8 410	*6 940	*6 940	*6 310	5 320	*6 200	4 910	7.88
	3.0					*10 740	*10 740	*7 970	7 160	*6 740	5 170	*6 430	4 490	8.24
	1.5					*12 500	10 220	*8 930	6 840	*7 220	5 020	6 430	4 340	8.31
	0 (Ground)					*13 080	9 980	*9 500	6 650	7 370	4 910	6 610	4 440	8.10
	-1.5			*9 490	*9 490	*12 780	9 970	*9 510	6 590	7 350	4 900	7 250	4 840	7.58
	-3.0			*15 900	*15 900	*11 670	10 110	*8 750	6 680			*7 580	5 790	6.69
	-4.5			*12 410	*12 410	*9 180	*9 180					*7 690	*7 690	5.23
Boom 6.0 m Arm 2.96 m Counterweight 6 200 kg	6.0							*5 700	*5 700	*4 880	*4 880	*4 330	*4 330	7.67
	4.5					*7 640	*7 640	*6 470	*6 470	*5 930	5 380	*4 350	*4 350	8.32
	3.0					*9 990	*9 990	*7 560	7 240	*6 440	5 210	*4 530	4 180	8.65
	1.5					*12 000	10 360	*8 630	6 900	*7 000	5 040	*4 910	4 050	8.72
	0 (Ground)					*12 950	10 020	*9 340	6 670	7 360	4 910	*5 560	4 120	8.52
	-1.5			*9 330	*9 330	*12 950	9 940	*9 540	6 570	7 300	4 850	6 640	4 440	8.03
	-3.0	*10 830	*10 830	*15 510	*15 510	*12 140	10 030	*9 070	6 600			*7 210	5 190	7.20
	-4.5			*14 040	*14 040	*10 180	*10 180					*7 500	7 040	5.87

EQUIPMENT

● : Standard equipment ○ : Optional equipment - : Not applicable

ENGINE	ZX250-7 / ZX260LC-7
Aftertreatment device	● ●
Air cleaner double filters	● ●
Alternator 60 A	● ●
Auto idle system	● ●
Auto shut-down control	● ●
Cartridge-type engine oil filter	● ●
Cartridge-type fuel main filter	● ●
ConSite OIL (sensor)*	● ●
DEF/AdBlue® tank inlet strainer and extension filler	● ●
DEF/AdBlue® tank	● ●
Dry-type air filter with evacuator valve (with air filter restriction indicator)	● ●
Dust-proof indoor net	● ●
ECO/PWR mode control	● ●
Electrical fuel feed pump	● ●
Engine oil drain coupler	● ●
Expansion tank	● ●
Fan guard	● ●
Fuel cooler	● ●
Fuel pre-filter with water separator	● ●
Isolation-mounted engine	● ●
Maintenance free pre-cleaner	● ●
Radiator, oil cooler and intercooler	● ●

HYDRAULIC SYSTEM	ZX250-7 / ZX260LC-7
Auto power lift	● ●
ConSite OIL (sensor)*	● ●
Control valve with main relief valve	● ●
Full flow filter	● ●
High mesh full flow filter with restriction indicator	○ ○
Hose rupture valve for arm cylinder	● ●
Hose rupture valve for boom	● ●
Pilot filter	● ●
Power boost	● ●
Suction filter	● ●
Swing dampener valve	● ●
Two extra ports for control valve	● ●
Variable reliefvalve for breaker and crusher	● ●
Work mode selector	● ●

* Engine oil and hydraulic oil monitoring sensor.

CAB	ZX250-7 / ZX260LC-7
All-weather sound suppressed steel cab	● ●
Auto control air conditioner	● ●
AUX function lever (Breaker assist)	○ ○
Bluetooth® integrated DAB+radio	● ●
Console height adjustment	● ●
CRES VII (center pillar reinforced structure) cab	● ●
Drink holder with hot and cool function	● ●
Electric double horn	● ●
Engine shut-off switch	● ●
Equipped with reinforced, tinted (Green color) glass windows	● ●
Evacuation hammer	● ●
Floor mat	● ●
Footrest	● ●
Front window washer (1 points)	● ●
Front window washer (2 points)	○ ○
Glove compartment	● ●
Hands-free calling device	● ●
Hot and cool box	● ●
Intermittent windshield wipers	● ●
Key cylinder light	● ●
Laminated round glass window	○ ○
LED room light	● ●
Magazine rack	● ●
OPG front guard Level II (ISO10262 : 1998) compliant	○ ○
OPG top guard Level I (ISO10262 : 1998) compliant	● ●
OPG top guard Level II (ISO10262 : 1998) compliant	● ●
Wide view wiper	○ ○
Pilot shut-off lever	● ●
Power outlet 12 V and 24 V	● ●
Rain guard (without OPG front guard)	○ ○
Rear tray	● ●
Retractable seat belt	● ●
ROPS (ISO12117-2: 2008) compliant cab	● ●
Rubber radio antenna	● ●
Seat : air suspension seat with heater	● ●
Seat adjustment part : backrest, armrest, height and angle, slide forward / back	● ●
Seat belt reminder	● ●
Short wrist control levers	● ●
Smartphone holder	● ●
Sunscreen roller type (multi-use front or side and rear window)	● ●
Transparent roof with slide curtain	● ●
USB power supply	● ●
Windows on front, upper, lower and left side can be opened	● ●
2 speakers	● ●
4 fluid-filled elastic mounts	● ●
8 inch monitor	● ●

MONITOR SYSTEM	ZX250-7 / ZX260LC-7
Alarms: overheat, engine warning, engine oil pressure, alternator, minimum fuel level, hydraulic filter restriction, air filter restriction, work mode, overload, SCR system trouble, etc	● ●
Alarm buzzers: overheat, engine oil pressure, overload, SCR system trouble, etc	● ●
Display of meters: water temperature, hour, fuel rate, clock, DEF/AdBlue® rate, etc	● ●
Other displays: work mode, auto-idle, glow, rearview monitor, operating conditions, etc	● ●
35 languages selection	● ●

LIGHTS	ZX250-7 / ZX260LC-7
Additional boom LED light with cover	○ ○
Additional cab roof front LED lights	○ ○
Additional cab roof rear LED light	● ●
LED lights for camera (side and rear view camera)	● ●
Rotating lamp	○ ○
2 working LED lights	● ●

UPPER STRUCTURE	ZX250-7 / ZX260LC-7
Aerial Angle® (270-degree view camera system)	● ●
Batteries 2 x 126 Ah	● ●
Battery disconnect switch	● ●
Body top handrail	● ●
Counterweight 6 200 kg	● ●
Counterweight 5 600 kg	- ○
Fuel level float	● ●
Hydraulic oil level gauge	● ●
Lockable fuel refilling cap	● ●
Lockable machine covers	● ●
Lockable tool box	● ●
Platform handrail	● ●
Skid-resistant plates	● ●
Swing parking brake	● ●
Undercover	● ●
Undercover 6.0 mm reinforced	○ ○
Utility space	● ●

SPECIFICATIONS

● : Standard equipment ○ : Optional equipment – : Not applicable

UNDERCARRIAGE	ZX250-7 / ZX260LC-7	
Bolt-on sprocket	●	●
Reinforced track links with pin seals	●	●
Shoe: 600 mm reinforced triple grouser	●	●
Shoe: 700 mm triple grouser	○	○
Shoe: 800 mm triple grouser	○	○
Shoe: 900 mm triple grouser	–	○
Towing hole for light weight object	●	●
Track undercover	●	●
Travel direction mark on track frame	●	●
Travel motor covers	●	●
Travel parking brake	●	●
Upper and lower rollers	●	●
3 track guards (each side)	●	●
4 tie down brackets	●	●
Greasing type track adjuster	●	●

ATTACHMENTS	ZX250-7 / ZX260LC-7	
Accessories for 2 speed selector	○	○
Additional pump (50 L/min)	○	○
Assist piping	○	○
Breaker and crusher piping	●	●
Pilot accumulator	●	●

MISCELLANEOUS	ZX250-7 / ZX260LC-7	
ConSite	●	●
Global e-Service	●	●
Onboard information controller	●	●
Standard tool kit	●	●
Travel alarm	●	●
Satellite communication system unit	●	●
Level indicator	●	●

FRONT ATTACHMENTS	ZX250-7 / ZX260LC-7	
Arm tip remote lubrication	●	●
Casted bucket link A	●	●
Centralized lubrication system	●	●
Dirt seal on all bucket pins	●	●
Flanged pin	●	●
HN bushing	●	●
Lower arm reinforcement	●	●
Reinforced resin thrust plate	●	●
WC (tungsten-carbide) thermal spraying	●	●
Reinforced bucket link B	●	●

Standard and optional equipment may vary by country, so please consult your Hitachi dealer for details.

Prior to operating this machine, including satellite communication system, in a country other than a country of its intended use, it may be necessary to make modifications to it so that it complies with the local regulatory standards (including safety standards) and legal requirements of that particular country. Please do not export or operate this machine outside the country of its intended use until such compliance has been confirmed. Please contact your Hitachi dealer in case of questions about compliance.

These specifications are subject to change without notice.

Illustrations and photos show the standard models, and may or may not include optional equipment, accessories, and all standard equipment with some differences in color and features. Before use, read and understand the Operator's Manual for proper operation.