

ZAXIS-7 series

HITACHI

Reliable solutions

ZAXIS690LCH



HYDRAULIC EXCAVATOR

Model code : ZX690LCH-7

Engine rated power : 348 kW (ISO 14396) /
347 kW (ISO 9249)

Operating weight : 69 400 – 71 400 kg

Bucket ISO heaped : 2.9 – 4 m³



YOU'RE IN CONTROL

You're at the heart of Hitachi's design for its latest range of excavators. To continuously improve on previous generation machines we've focused on enhancing your experience in the cab as an operator.

We've considered the challenges you face as the owner of a successful business. And we've zoomed in on the ways in which we can support you over the life cycle of your machine.

By putting you at the heart of the Zaxis-7 range, we invite you to take control – over your workspace and your fleet. And by working in partnership, we will help you to create your vision.



INSIDE



4. Complete Control
In control of your assets



6. Increase your safety
Be in control of your environment



8. Boost your uptime
Improve your profit

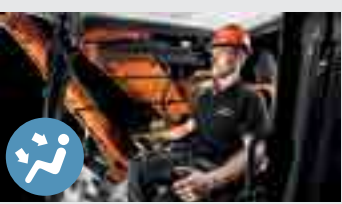

11. Control Zone
Feel the difference



12. Get More from your machine
In control of your performance



14. Specifications
Know your machine



COMPLETE CONTROL

The new Zaxis-7 range of large excavators puts you firmly in control, so you can feel assured of your machine's performance and supported by the technological expertise and services that Hitachi provides.



The expanded cab interior provides a more comfortable working environment.



Integrated console and seat suspension gives a greater sense of control, and helps to reduce fatigue.



Visibility of the job site is excellent thanks to the Aerial Angle® camera system and new LCD monitor.



Sensors monitor oil continuously and contribute to preventative maintenance, helping to reduce downtime.



ConSite Pocket app allows you to manage and monitor your fleet remotely.



Options such as Hitachi ground engaging tools enable you to enhance the performance of your excavator.



Improved access to components ensures maintenance is quick and easy.



The new HIOS-V hydraulic system reduces fuel consumption and increases front speed to enhance productivity.



The ECO gauge on the monitor indicates how to lower fuel consumption and reduce costs.



INCREASE YOUR SAFETY

Your ability to work safely is vital, not only for your own wellbeing, but also for the successful completion of any project. To protect yourself and your machine from potential hazards, the new Hitachi Zaxis-7 excavators give you a superior view of your surroundings, so you can see the job site from all angles.

The visibility you enjoy from the cab includes an exceptional 270-degree bird's-eye view with the Aerial Angle® camera system. You can choose from six image options to view the machine's immediate environment, which enables you to control your own safety – as well as that of those around you.

To help you to work more confidently and efficiently, even in the most challenging of conditions, Zaxis-7 excavators are fitted with some impressive new features. From the LED work lights and the windscreen wiper with an increased sweeping area, to the large reflective strips on the counterweight and roller sunshades, you'll have the visibility you need when it matters most.

Attention to detail is also fundamental to a safe working environment – and the repositioning of the pilot shutoff lever is a perfect example. It is now within easy reach to prevent any unintentional actions.



The pilot shutoff lever offers enhanced safety in the cab.



Choose between different image layouts to suit your working environment.



LED work lights improve visibility in challenging conditions.

BOOST YOUR UPTIME

Completing a project on time and on budget depends on the ability of your construction equipment to perform all day, every day. That's why Hitachi owners have profited from generations of ultra-reliable and durable machinery – and the Zaxis-7 range is no exception.

The latest Hitachi large excavators have been built to last, so that you can remain in complete control of your assets. They have been tested rigorously and continuously at dedicated facilities in Japan with the goal of significantly boosting your uptime.

As a result, a wide range of durable new components have been fitted to the latest Stage-V compliant machines – even down to the detail of the rigidity of the door hinges. Now standard on our Zaxis-7 range are hydraulic and engine oil monitoring sensors that help to reduce downtime and running costs.

Downtime is prevented by the durable after-treatment system, and also minimised by the priority given to easy maintenance and cleaning – saving you time and money. Peace of mind comes from such features as the two-way disconnect switch. This makes it possible to shut down power without resetting data on the monitor and prevents the battery from discharging during welding.



The radiator is easy to clean and maintain.



Components are conveniently accessible for daily maintenance.



Access to the upper structure is easy via a new step.



A fuel saving of up to 22% is achieved with the HIOS V hydraulic system.





1

2

3

4

5

16

15

13

14

6

7

8

9

11

12

10

CONTROL ZONE

Enhanced comfort and safety features are at your fingertips in the refined cab of Zaxis-7 excavators, giving you the power to perform productively, with ease and reduced fatigue.

- 1 **Increased sweeping area of wide view wiper** enhances visibility in difficult working conditions.
- 2 **Air conditioning and audio** are easily controlled via the monitor.
- 3 **Low-reflective colour 8" LCD monitor** is easy to view and navigate.
- 4 **USB power supply and smartphone holder** helps you stay connected.
- 5 **Drinks holder** is easy to detach for cleaning.
- 6 **Additional joystick controls** for effortless operation.
- 7 **Ergonomic design** gives you convenient access to controls.
- 8 **Bluetooth®** for hands-free calls and **DAB+** radio for music while you work.
- 9 **Multifunctional control panel** makes operation easier.
- 10 **Improved sound isolation** makes this one of the quietest cabs in the market.
- 11 **User-friendly storage space** keeps your workspace tidy and clutter-free.
- 12 **12v and 24v outlets** for your electrical devices.
- 13 **One-touch adjustment lever for console** so you can work comfortably in the optimum position.
- 14 **Integrated console and seat suspension** gives a greater sense of control and helps to reduce fatigue.
- 15 **Increased legroom** creates a more spacious cab.
- 16 **Optimal pedal layout** helps to reduce fatigue.



Operation is easy with ergonomically designed controls and switches.



Bluetooth® connection for hands-free calls while you work.

GET MORE FROM YOUR MACHINE

Designed to work in perfect harmony with your machine, Hitachi preferred durable hydraulic breakers, hydraulic hitches, buckets and Ground Engaging Tools (GET) will increase your profit by maximising productivity and uptime. Manufactured to the same high standards as all Hitachi construction equipment, they offer unrivalled reliability and exceptional performance.

Buckets

You can increase the versatility of your excavator by choosing the right bucket for the job. For loading light materials or heavy-duty work, Hitachi supplied buckets can be customised to meet your needs. You have a wide range of options to choose from Hitachi supplied buckets with different capacities and widths.

Ground engaging tools

You can enhance the digging power and productivity of your excavator or wheel loader with Hitachi GET. Quick and safe to install and replace, they fit precisely to your attachments and can be tailored to suit the task. Using Hitachi GET can reduce your maintenance costs and downtime, lower fuel consumption and enhance the overall performance of your machine.

Breakers

High-performance hydraulic breakers – approved by Hitachi – are perfectly suited to large excavators. They are easy to maintain and user-friendly, and their high-quality materials ensure a long lifetime. This means reduced maintenance costs, fewer replacement parts and minimal downtime.



Attachments can be customised to suit the application.



Breakers are lightweight with high impact energy.



Hitachi GET include teeth and reliable adapters to ensure a precise fit.
*Not available in all markets



A variety of boom and arm types are available to suit tough environments and heavy-duty tasks.



SPECIFICATIONS

ENGINE	
Model	Isuzu 6WG1
Type	4-cycle water-cooled, common rail direct injection
Aspiration	Variable geometry turbocharged, intercooled, cooled EGR
Aftertreatment	DOC+CSF+SCR system
No. of cylinders	6
Rated power	
ISO 14396 : 2002 gross	348 kW at 1 800 min ⁻¹
ISO 9249 : 2007 net	347 kW at 1 800 min ⁻¹
SAE J1349 : net	347 kW at 1 800 min ⁻¹
Maximum torque	2 050 Nm at 1 300 min ⁻¹
Piston displacement	15.681 L
Bore and stroke	147 mm x 154 mm
Batteries	2 x 12 V / 170 Ah

HYDRAULIC SYSTEM			
Hydraulic Pumps			
Main pumps	2 variable displacement axial piston pumps		
Maximum oil flow	2 x 489 L/min		
Pilot pump	1 gear pump		
Maximum oil flow	50 L/min		
Hydraulic Motors			
Travel	2 axial piston motors with parking brake		
Swing	2 axial piston motors		
Relief Valve Settings			
Implement circuit	31.9 MPa		
Swing circuit	29.4 MPa		
Travel circuit	34.3 MPa		
Pilot circuit	3.9 MPa		
Power boost	34.3 MPa		
Hydraulic Cylinders			
	Quantity	Bore	Rod diameter
Boom	2	190 mm	130 mm
Arm	1	200 mm	140 mm
Bucket	1	180 mm	130 mm
BE-Bucket	1	190 mm	130 mm

UPPERSTRUCTURE	
Revolving Frame	
D-section frame for resistance to deformation.	
Swing Device	
Axial piston motor with planetary reduction gear is bathed in oil. Swing parking brake is spring-set/hydraulic-released disc type.	
Swing speed	9 min ⁻¹
Swing torque	194 kNm

UNDERCARRIAGE	
Tracks	
Track shoes with triple grousers made of induction-hardened rolled alloy. Heat-treated connecting pins with dirt seals. Hydraulic (grease) track adjusters with shock-absorbing recoil springs.	
Numbers of Rollers and Shoes on Each Side	
Upper rollers	3
Lower rollers	8
Track shoes	47
Track guards	1
Travel Device	
Each track driven by axial piston motor through reduction gear for counterrotation of the tracks. Parking brake is spring-set/hydraulic-released disc type. Automatic transmission system: High-Low.	
Travel speeds	High : 0 to 5 km/h
	Low : 0 to 3.4 km/h
Maximum traction force	483 kN
Gradeability	70% (35 degree) continuous

SERVICE REFILL CAPACITIES	
Fuel tank	900.0 L
Engine coolant	76.0 L
Engine oil	62.0 L
Pump drive	6.2 L
Swing device	10.5 L
Travel device (each side)	13.5 L
Hydraulic system	750.0 L
Hydraulic oil tank	380.0 L
DEF/AdBlue® tank	95.0 L

ENVIRONMENT	
Engine Emissions	EU Stage V
Sounds Level	
Sound level in cab according to ISO 6396 : 2008	74 LpA dB(A)
External sound level according to ISO 6395 : 2008 and EU Directive 2000/14/EC	108 LwA dB(A)
Air Conditioning System	
The air conditioning system contains fluorinated greenhouse gases. Refrigerant type: HFC-134a, GWP: 1430, Amount: 1.05kg, CO2e: 1.50ton.	

WEIGHTS AND GROUND PRESSURE

Operating Weight and Ground Pressure

Bucket Capacity	Boom type	Arm type	Shoe grouser type	Shoe width (mm)	Operating weight (kg)	Ground pressure (kPa)
2.9 m ³ Rock bucket (ISO heaped)	7.8 m H	3.6 m H	Double	650 mm	69 400	104
			Double	750 mm	69 700	91
			Double	900 mm	70 800	77
4.0 m ³ Rock bucket (ISO heaped)	6.8 m BE	2.9 m BE	Double	650 mm	70 000	105
			Double	750 mm	70 400	92
			Double	900 mm	71 400	77

BUCKET AND ARM DIGGING FORCE

Unit: kN

	ZAXIS 690LCH	
	Boom 6.8 m BE	Boom 7.8 m H
Arm length	Arm 2.9 m BE	Arm 3.6 m H
Bucket Digging Force* at Power Boost ISO 6015	369	324
Bucket Digging Force* at Power Boost SAE : PCSA	332	286
Arm Crowd Force* at Power Boost ISO 6015	306	255
Arm Crowd Force* at Power Boost SAE : PCSA	297	246

* At power boost

SPECIFICATIONS

WORKING RANGES

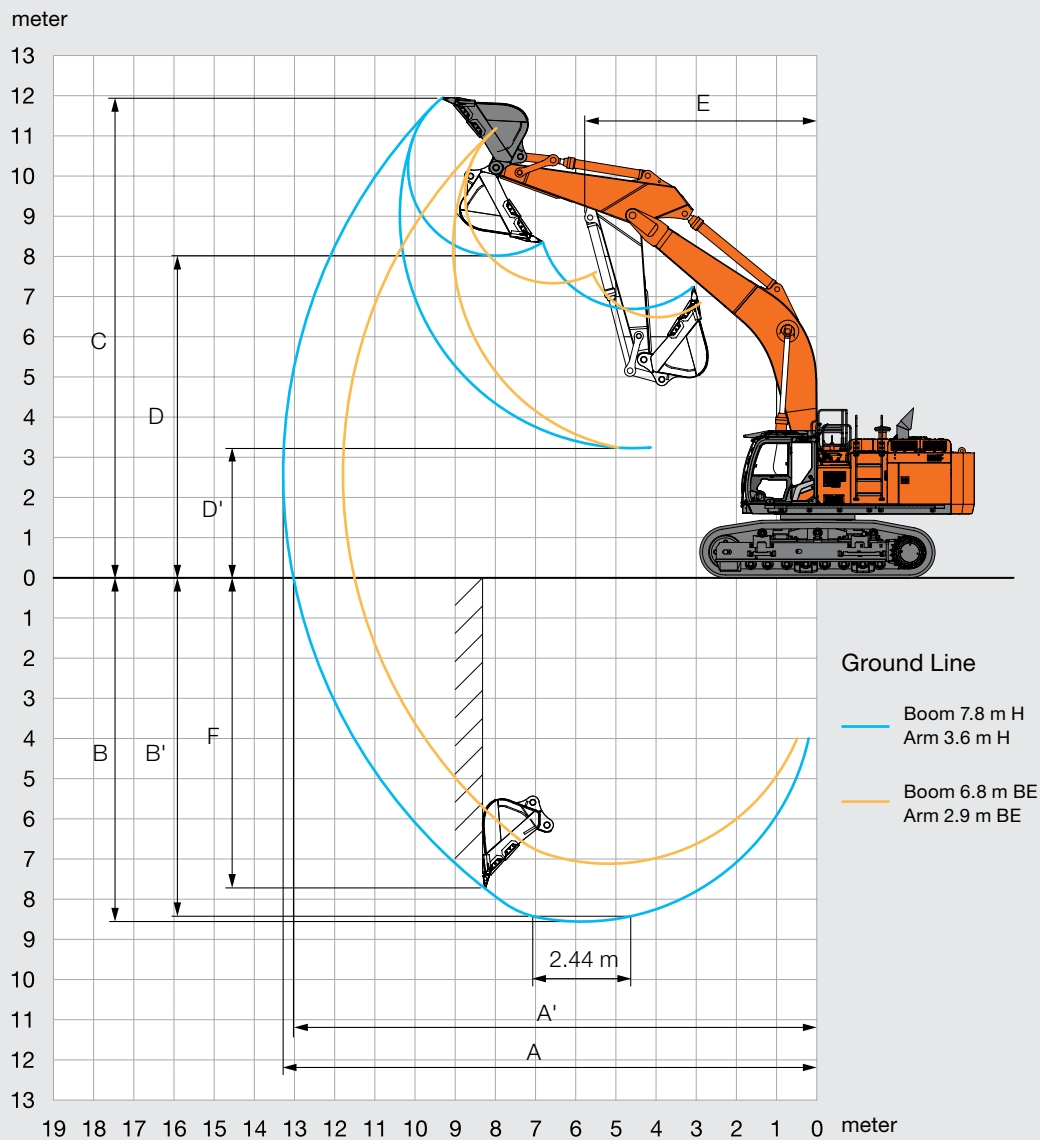

Unit: mm

	ZX690LCH-7	
	Boom 6.8 m BE	Boom 7.8 m H
Arm length	Arm 2.9 m BE	Arm 3.6 m H
A Max. digging reach	11 800	13 280
A' Max. digging reach (on ground)	11 500	13 030
B Max. digging depth	7 120	8 560
B' Max. digging depth for 2.44 m level	6 970	8 420
C Max. cutting height	11 190	11 940
D Max. dumping height	7 330	8 020
D' Min. dumping height	3 200	3 230
E Min. swing radius	5 240	5 780
F Max. vertical wall digging depth	5 280	7 720

Excluding track shoe lug

DIMENSIONS

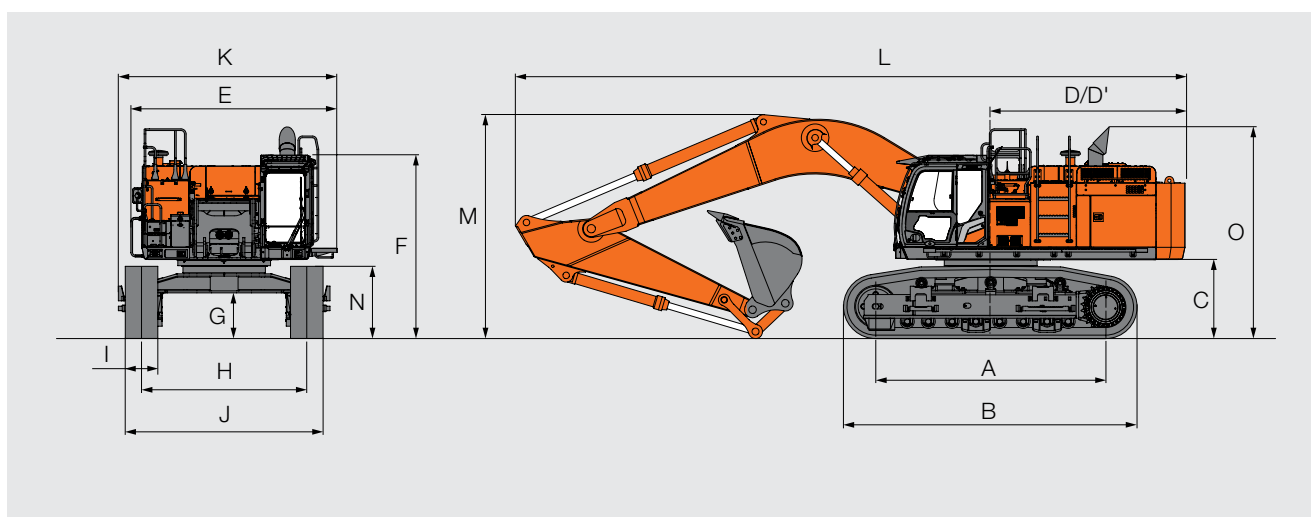

Unit: mm

		ZX690LCH-7		
A	Distance between tumbler	4 590		
B	Undercarriage length	5 840		
*C	Counterweight clearance	1 530		
D	Rear-end swing radius	4 020		
D'	Rear-end length	3 980		
E	Overall width of upperstructure	4 090		
F	Overall height of cab	3 660		
*G	Min. ground clearance	860		
H'	Track gauge : Extended / Retracted	3 300 / 2 830		
I	Track shoe width	G 650	G 750	G 900
J	Undercarriage width : Extended / Retracted	3 950 / 3 480	4 050 / 3 580	4 200 / 3 730
K	Overall width	4 360		
L	Overall length	13 500		
M	Overall height of boom	4 460		
N	Track height	1 440		
O	Overall height of base machine	4 230		

¹ Excluding track shoe lug G: Grouser shoe² Equipped with H-boom 7.8 m and H-arm 3.6 m

Backhoe Buckets

Bucket	Capacity (m3)		Width (mm)		No. of teeth	Weight (kg)	Recommendation	
	ISO heaped	CECE heaped	Without side cutters	With side cutters			ZX690LCH-7	
							Boom 6.8 m BE	Boom 7.8 m H
						Arm 2.9 m BE	Arm 3.6 m H	
Rock bucket	2.9	2.5	1 690	1 690	5	2 850	–	●
	3.3	2.9	1 790	1 790	5	3 110	●	–
	4.0	3.6	1 950	1 970	5	3 720	●	–
Ripper bucket	1.5	1.3	–	1 310	3	3 150	–	●
	1.8	1.6	–	1 570	3	3 750	●	–
One-point ripper	–	–	–	–	1	1 800	●	●

● Heavy-duty service – Not applicable

TRANSPORTATION

BASIC MACHINE (WITHOUT COUNTERWEIGHT)

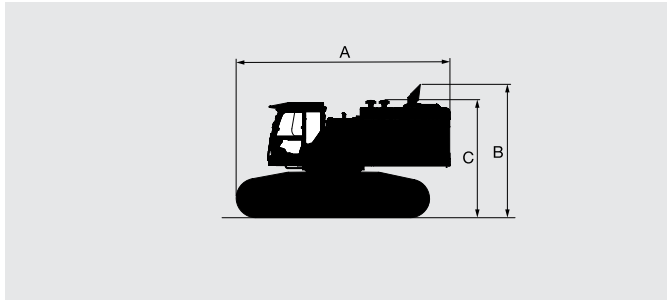

SIDE FRAME

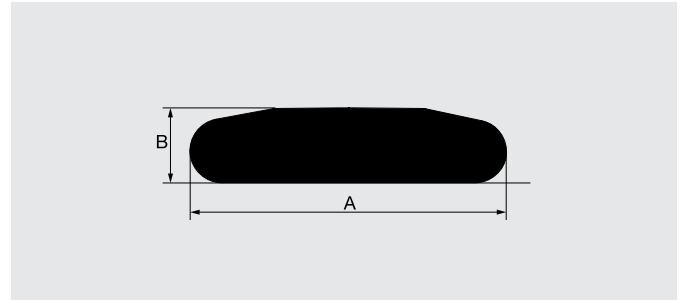

BUCKET

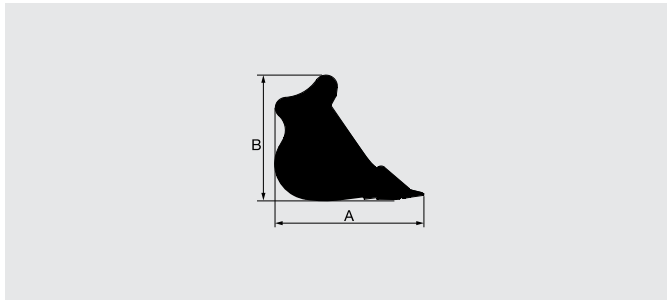

ARM

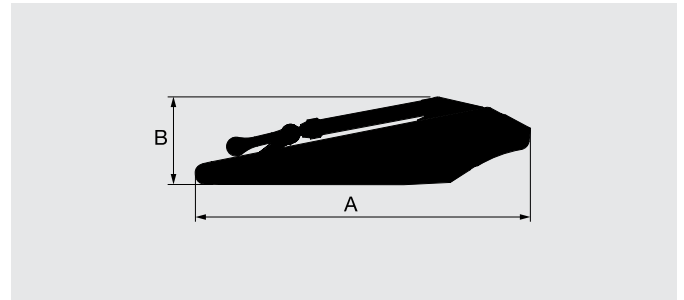

BOOM

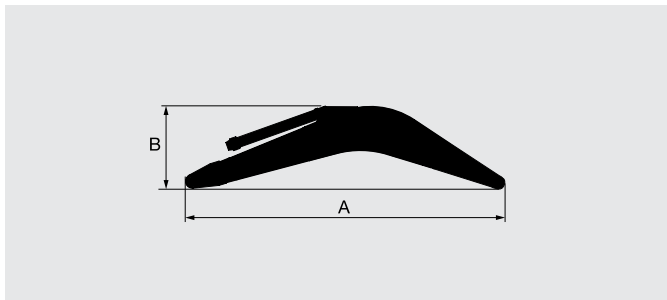

BOOM CYLINDERS 550 kg X 2
Overall height: 380 mm

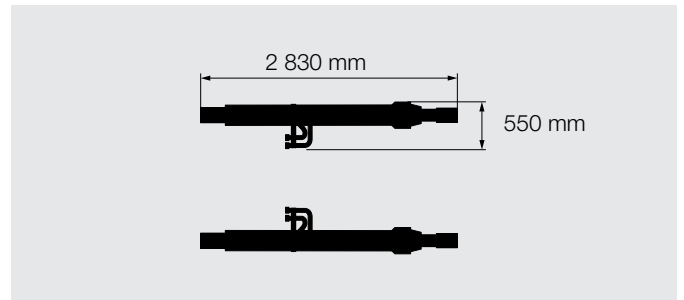

HOSE OF BOOM CYLINDERS
7 kg X 2 / 10 kg X 2

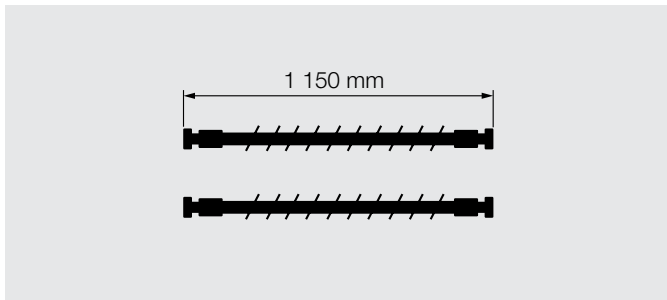

LEFT SIDEWALK

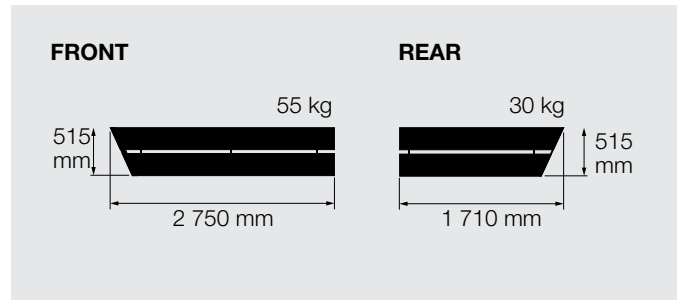

UPPER STRUCTURE

Overall width: 3 420 mm / Weight: 22 700 kg

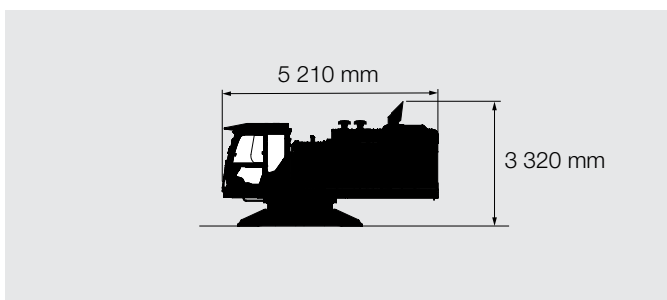

COUNTERWEIGHT

Overall height: 1 660 mm / Weight: 10 400 kg

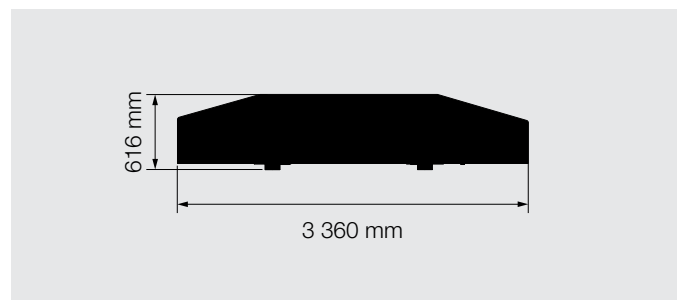

BASIC MACHINE (WITHOUT COUNTERWEIGHT)

	Shoe width (mm)	A (mm)	B (mm)	C ¹ (mm)	Overall width* ² (mm)	Weight (kg)
ZX690LCH-7	650	6 240	4 230	3 760	3 600	44 300
	750	6 240	4 230	3 760	3 600	44 700
	900	6 240	4 230	3 760	3 730	45 700

¹ Without exhaust funnel

² Undercarriage retracted without truck sidestep

SIDE FRAME

	Shoe width (mm)	A: Length (mm)	B: Height (mm)	Overall width (mm)	Weight (kg)
ZX690LCH-7	650	5 850	1 450	1 250	10 800
	750	5 850	1 450	1 250	11 000
	900	5 850	1 450	1 320	11 500

BOOM

Boom	A: Length (mm)	B: Height (mm)	C: Overall width (mm)	Weight (kg)
6.8 BE	7 130	2 550	1 390	6 140
7.8 H	8 130	2 330	1 390	6 430

ARM

Arm	A (mm)	B (mm)	Overall width (mm)	Weight (kg)
2.9 BE	4 370	1 680	790	3 720
3.6 H	5 110	1 430	790	3 630

BUCKET

Bucket	Capacity (m ³)		A (mm)	B (mm)	Overall width (mm)	Weight (kg)
	ISO heaped	CECE heaped				
Rock bucket	2.9	2.5	2 290	1 770	1 690	2 850
	3.3	2.9	2 230	1 890	1 790	3 110
	4.0	3.6	2 370	1 930	1 970	3 720
	2.9	2.5	2 270	1 800	1 740	3 390
	3.3	2.9	2 270	1 920	1 840	3 990

MACHINE CAPACITIES

- Notes: 1. Ratings are based on ISO 10567 : 2007.
 2. Machine capacity does not exceed 75% of tipping load with the machine on firm, level ground or 87% full hydraulic capacity.
 3. The load point is the center line of the bucket pivot mounting pin on the arm.
 4. *Indicates load limited by hydraulic capacity.
 5. 0 m = Ground.

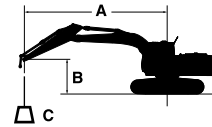

A: Load radius
 B: Load point height
 C: Machine capacity

For machine capacities, subtract installed attachment and quick hitch weight from machine capacities.

To determine lifting capacities, apply "Rating over side or 360 degrees" machine capacities from the table and deduct weight of installed attachment and quick hitch. Optional feature may affect machine performance.

ZX690LCH-7

Rating over-front Rating over-side or 360 degrees Unit : kg

Conditions	Load point height m	Load radius												At max. reach		
		3.0 m		4.5 m		6.0 m		7.5 m		9.0 m		10.0 m		meter		
Boom 6.8 m BE Arm 2.9 m BE Counterweight 10 400 kg	7.5							*16 660	*16 660					*12 490	*12 490	8.2
	6.0					*19 550	*19 550	*17 380	*17 380					*12 190	*12 190	9.0
	4.5					*22 420	*22 420	*18 760	17 510	*16 820	13 190			*12 310	12 250	9.4
	3.0					*25 310	23 250	*20 280	16 800	*17 470	12 830			*12 790	11 630	9.6
	1.5					*27 260	22 260	*21 460	16 200	17 570	12 510			*13 720	11 510	9.5
	0 (Ground)					*27 830	21 740	*21 910	15 820	17 370	12 330			*15 270	11 900	9.2
	-1.5			*35 050	34 260	*26 950	21 610	*21 270	15 720					*17 510	12 970	8.7
	-3.0	*37 780	*37 780	*31 110	*31 110	*24 320	21 840	*18 650	15 960					*17 450	15 250	7.8
	-4.5			*24 230	*24 230	*18 340	*18 340	*11 160						*16 370	*16 370	6.4
Boom 7.8 m H Arm 3.6 m H Counterweight 10 400 kg	7.5									*13 380	*13 380			*9 280	*9 280	9.9
	6.0							*15 530	*15 530	*14 040	13 600	*9 750	*9 750	*9 310	*9 310	10.5
	4.5					*21 370	*21 370	*17 290	*17 290	*15 000	13 130	*13 580	10 270	*9 570	*9 570	10.9
	3.0					*24 450	22 710	*19 070	16 490	*16 040	12 640	13 980	10 000	*10 070	9 180	11.1
	1.5					*26 460	21 650	*20 460	15 800	*16 910	12 210	13 720	9 750	*10 870	9 050	11.0
	0 (Ground)			*15 110	*15 110	*27 170	21 100	*21 210	15 350	16 910	11 890	13 530	9 580	*12 090	9 230	10.8
	-1.5			*23 200	*23 200	*26 770	20 920	*21 200	15 130	16 740	11 740			13 850	9 790	10.3
	-3.0	*22 480	*22 480	*32 260	*32 260	*25 320	21 000	*20 260	15 140	*16 360	11 770			*14 960	10 900	9.6
	-4.5	*32 910	*32 910	*28 270	*28 270	*22 550	21 340	*17 960	15 390					*15 070	13 050	8.5
-6.0			*21 920	*21 920	*17 430	*17 430							*14 480	*14 480	6.9	

EQUIPMENT

● : Standard equipment ○ : Optional equipment – : Not applicable

ENGINE	ZX690LCH-7
Aftertreatment device	●
Air cleaner double filters	●
Alternator 90 A	●
Auto idle system	●
Auto shut-down control	●
Cartridge-type engine oil filter	●
Cartridge-type fuel main filter	●
ConSite OIL (sensor)*	●
DEF/AdBlue® tank inlet strainer and extension filler	●
DEF/AdBlue® tank with ISO magnet adapter	●
Dry-type air filter with evacuator valve (with air filter restriction indicator)	●
Dust-proof indoor net	●
ECO/PWR mode control	●
Electrical fuel feed pump	●
Engine oil drain coupler	●
Expansion tank	●
Fan guard	●
Fuel cooler	●
Fuel pre-filter with water separator	●
Isolation-mounted engine	●
Maintenance free pre-cleaner	●
Radiator, oil cooler and intercooler	●

HYDRAULIC SYSTEM	ZX690LCH-7
Auto power lift	●
Boom mode selector system	●
ConSite OIL (sensor)*	●
Control valve with main relief valve	●
Drain filter	●
Engine speed sensing system	●
Extra port for control valve	●
Hose rupture valve for arm	○
Hose rupture valve for boom	○
Pilot filter	●
Power boost	●
Shockless valve in pilot circuit	●
Suction filter	●
Work mode selector	●

* Engine oil and hydraulic oil monitoring sensor.

CAB	ZX690LCH-7
All-weather sound suppressed steel cab	●
Auto control air conditioner	●
Bluetooth® integrated DAB+radio	●
Console height adjustment	●
CRES VII (center pillar reinforced structure) cab	●
Control lever auto-lock	●
Drink holder with hot and cool function	●
Electric double horn	●
Engine shut-off switch	●
Equipped with reinforced, tinted (Green color) glass windows	●
Evacuation hammer	●
Floor mat	●
Footrest	●
Front window washer (2 points)	●
Glove compartment	●
Hands-free calling device	●
Hot and cool box	●
Intermittent windshield wipers	●
Key cylinder light	●
Laminated round glass window	●
LED room light	●
Magazine rack	●
OPG front guard Level II (ISO10262) compliant	○
OPG top guard Level II (ISO10262) compliant	●
Pilot shut-off lever	●
Power outlet 12 V and 24 V	●
Rear tray	●
Retractable seat belt	●
Rubber radio antenna	●
Seat : air suspension seat with heater	●
Seat adjustment part : backrest, armrest, height and angle, slide forward / back	●
Seat belt reminder	●
Short wrist control levers	●
Smartphone holder	●
Sunscreen roller type (multi-use front or side and rear window)	●
Transparent roof with slide curtain	●
USB power supply	●
Wide view wiper	●
Windows on front, upper, lower and left side can be opened	●
2 speakers	●
6 fluid-filled elastic mounts	●

MONITOR SYSTEM	ZX690LCH-7
Alarms: overheat, engine warning, engine oil pressure, alternator, minimum fuel level, hydraulic filter restriction, air filter restriction, work mode, overload, SCR system trouble, etc	●
Alarm buzzers: overheat, engine oil pressure, overload, SCR system trouble, etc	●
Display of meters: water temperature, hour, fuel rate, clock, DEF/AdBlue® rate, etc	●
Other displays: work mode, auto-idle, glow, rearview monitor, side view monitor, operating conditions, etc	●
35 languages selection	●

LIGHTS	ZX690LCH-7
Additional boom LED light with cover	○
Additional cab roof front 2 LED lights	●
Additional cab roof front 4 LED lights	○
Additional cab roof rear LED lights	●
LED lights for camera (side and rear view camera)	●
3 working LED lights	●

UPPER STRUCTURE	ZX690LCH-7
AERIAL ANGLE® (side and rear view camera)	●
Batteries 2 x 170 Ah	●
Body top handrail	●
Counterweight 10 400 kg	●
Electrical grease pump with hose-reel	●
Fuel level float	●
Hydraulic oil level gauge	●
Ladder	●
Lockable fuel refilling cap	●
Lockable machine covers	●
Lockable tool box	●
Platform handrail	●
Sidewalk (cab side)	●
Skid-resistant plates and handrails	●
Swing parking brake	●
Undercover	●
2 way disconnect switch	●

SPECIFICATIONS

● : Standard equipment ○ : Optional equipment – : Not applicable

UNDERCARRIAGE	ZX690LCH-7
Full track guard	●
Reinforced track links with pin seals	●
Shoe: 650 mm double grouser	●
Shoe: 750 mm double grouser	○
Shoe: 900 mm double grouser	○
Track undercover	●
Travel direction mark on track frame	●
Travel motor covers	●
Travel parking brake	●
Upper and lower rollers (with single-flange lower rollers)	●
Upper and lower rollers (with double-flange lower rollers)	●
4 tie down hooks	●

ATTACHMENTS	ZX690LCH-7
Accessories for breaker and crusher	○
Accessories for 2 speed selector	○
Pilot accumulator	●

MISCELLANEOUS	ZX690LCH-7
ConSite	●
Global e-Service	●
Onboard information controller	●
Standard tool kit	●
Theft prevention system**	○

FRONT ATTACHMENTS	ZX690LCH-7
Arm 2.9 m BE	○
Arm 3.6 m H	●
Boom 6.8 m BE	○
Boom 7.8 m H	●
Centralized lubrication system	●
Cylinder hose protectors arm	●
Cylinder hose protectors boom	●
Cylinder hose protectors bucket	●
Damage prevention plate and square bars	●
Dirt seal on all bucket pins	●
Flanged pin	●

Standard and optional equipment may vary by country, so please consult your Hitachi dealer for details.

** Hitachi Construction Machinery cannot be held liable for theft, any system will just minimize the risk of theft.

Prior to operating this machine, including satellite communication system, in a country other than a country of its intended use, it may be necessary to make modifications to it so that it complies with the local regulatory standards (including safety standards) and legal requirements of that particular country. Please do not export or operate this machine outside the country of its intended use until such compliance has been confirmed. Please contact your Hitachi dealer in case of questions about compliance.

These specifications are subject to change without notice. Illustrations and photos show the standard models, and may or may not include optional equipment, accessories, and all standard equipment with some differences in color and features. Before use, read and understand the Operator's Manual for proper operation.