

ZW-6 series

HITACHI

Reliable Solutions

ZW370

Hitachi Construction Machinery Group
LANDCROS
Japanese Excellence—Reliable Solutions



WHEEL LOADER

Model code : ZW370-6

Engine output : 290 kW (389 hp)

Operating weight : 35 200 – 35 620 kg

Bucket ISO heaped : 4.8 – 6.2 m³

ZW370-6. NO COMPROMISE

Ideal for mining and quarrying, the new ZW-6 large wheel loaders have been designed to be exceptionally reliable and durable. They are built to deliver the highest levels of productivity in the most challenging working conditions.

Manufactured using market-leading technology and high-quality components, the ZW370-6 also offers excellent performance without compromising on efficiency, thanks to low levels of fuel consumption.



6. RENOWNED RELIABILITY



8. UNDENIABLE DURABILITY



10. POWERFUL VERSATILITY



12. QUALITY BUILT-IN



14. SUPERIOR TECHNOLOGY

DEMAND PERFECTION

Designed with an emphasis on operator comfort and safety, and the environment, the ZW370-6 has been developed to perfection. It incorporates innovative technology and industry-leading engineering to deliver exceptional productivity at the lowest possible cost of ownership.



Powerful performance

Quick power switch increases engine output when required.



Industry-leading safety

360° visibility from the cab.



Easy loading operation

More than 30% improved traction force for easier loading.



Easy to operate

Multifunctional monitor shows information at a glance.



Smooth operation

Ride control minimises machine pitching.



Strong components

Full box rear frame is a robust structure for heavy applications.





Durable design

Low mount lift arm cylinder prevents twisting of the front frame.



Low emissions

SCR system without DPF reduces NO_x from exhaust gas.



Environmentally friendly

More than 90% of parts are recyclable.



Improved fuel efficiency

Lock-up transmission and Stage IV-compliant engine.



Convenient access

Easy-to-open wide engine covers.



Superior comfort

Spacious cab with several storage compartments.



User-friendly

Effortless control with the optional Joystick Steering System.

RENOWNED RELIABILITY

Hitachi has an unrivalled reputation for producing reliable construction machinery. The new ZW-6 large wheel loaders have been developed to deliver a reliable and efficient performance on challenging mines and quarries. They are designed with several easy maintenance features to ensure minimal downtime.

Quick access

The engine covers open fully for the convenience of technical support. The urea tank is also located for safe and easy access from ground level. These help to ensure routine maintenance is completed quickly to ensure a reliable performance.

Improved fuel efficiency

The lock-up transmission has improved the fuel efficiency of the ZW370-6, which reduces running costs.

Easy maintenance

For safer and easier maintenance, the battery disconnect switch is now included as standard. This helps to avoid electrical

accidents and retain battery energy during long-term storage.

Reduced costs

The new Stage IV-compliant engine does not require a diesel particulate filter, which further reduces fuel consumption and maintenance costs.

Reliable performance

The lift arm contributes to the reliable performance of the ZW370-6. Its speed has been improved and it lowers smoothly for increased productivity. It is easy to control using the auto leveller.



Easy access to the engine compartment.



The battery is easy to maintain.



Stage IV engine reduces fuel consumption.



New rear grill protects radiator compartment.



Durable radiators are corrosion resistant.



i Hitachi wheel loaders are tested extensively in job site conditions around the world, in extreme temperatures.



UNDENIABLE DURABILITY

Difficult working environments are no match for the new range of Hitachi ZW-6 large wheel loaders. Designed and engineered to meet the needs of European mines and quarries, the ZW370-6 has a variety of robust features and reinforced components to enhance its durability.



The optional belly guard provides added protection.

Increased protection

The newly designed rear grill prevents raw material from the job site entering the radiator compartment. This provides greater protection.

Durable materials

High-quality radiators improve resistance to corrosion and enhance the overall durability of the ZW370-6 wheel loader.

Robust design

The ZW370-6 has been designed with a full box rear frame. This provides a robust structure that is capable of handling the rigours of heavy applications.

Additional reinforcement

The optional front belly guard protects the machine powertrain and driveshaft from potential damage caused by materials on the ground.

Strong structure

The low mount lift arm cylinder on the ZW370-6 creates a strong structure that guards against twisting of the front frame.

Efficient cooling

The reversible cooling fan, activated manually or automatically every 30 minutes, ensures that the radiator stays clean during operation.

POWERFUL VERSATILITY

Hitachi large wheel loaders are designed to operate smoothly and precisely, and are extremely user-friendly. Their powerful digging force, substantial loading capacity, impressive travel speeds and easy manoeuvrability makes them productive and efficient on a wide variety of applications, highlighting their versatility.

Greater traction force

The traction force has improved by 30% compared to the previous model. The result is a more efficient loading operation.

Efficient flexibility

The quick power switch increases engine output when more power is instantly required, or when driving uphill.

Effective control

To ensure a smooth drive on all kinds of terrain, the ride control feature prevents unnecessary pitching via the movement of lift arm cylinders.

High productivity

The simultaneous movement of the bucket and lift arm ensures a smooth digging operation. The bucket is prioritised after unloading so that the wheel loader quickly returns to digging, which helps to increase productivity.

Improved fuel economy

An auto power up function increases engine rpm as the ZW370-6 slows down when travelling uphill. This enhances its overall fuel economy by ensuring a shorter uphill journey time.



The ride control feature ensures a smooth performance.



Auto power up function helps to enhance fuel economy.



The quick power switch increases power when required.



ZW370

HITACHI



Urea is injected into the exhaust gas to reduce emissions.



Flow control system ensures smooth movement of the lift arm.



i The final checking and inspection procedure for each Hitachi wheel loader is typical of Hitachi's dedication to manufacturing products of unfailing quality in response to customer needs.



QUALITY BUILT-IN

The inherent quality of Hitachi large wheel loaders is evident in its effortless steering, unrivalled all-round visibility and quiet performance. Using only the finest design elements and components, followed by rigorous testing, Hitachi ensures its machines are able to lead the field in terms of quality, comfort and safety.



The optional Joystick Steering System provides exceptional control.

Reduced emissions

A selective catalytic reduction (SCR) system injects urea into exhaust gas to reduce nitrogen oxide from emissions. This cutting-edge technology not only helps the environment, but also complies with EU Stage IV emission regulations.

Improved comfort

The flow control system ensures the smooth movement of the lift arm when lowering. This means less pitching and a more comfortable experience for the operator.

Excellent visibility

The 360° panoramic view of the spacious cab creates a comfortable working environment, and helps to increase safety

and productivity. The rear-view camera, in combination with the unique two-piece counterweight, also contributes to excellent all-round visibility and safety on the job site.

Low-noise performance

To significantly reduce noise levels in the cab, sound insulation has been improved. As a result of this and the low-noise engine, operators can enjoy a quieter working environment.

User-friendly operation

The optional Joystick Steering System enables operators to reach high levels of productivity with effortless steering, and incorporates a number of useful functions.

SUPERIOR TECHNOLOGY

Hitachi large wheel loaders are developed using unique technology to meet industry demand for state-of-the-art machinery that offers high levels of productivity and performance at the lowest possible cost of ownership.

Reduced maintenance

A new Stage IV-compliant engine contains a high-volume cooled exhaust gas recirculation (EGR) system, a common rail-type fuel injection system and a diesel oxidation catalyst (DOC) without DPF. This helps to reduce fuel costs and maintenance requirements.

Multifunctional display

A large LCD colour monitor shows all the information required to operate the Hitachi ZW-6 wheel loader. This includes power modes, oil temperature, and fuel and urea levels, which is useful for easy maintenance. It also includes the display

for the easy-to-use rear camera, which enhances visibility for a safe operation.

Smaller environmental impact

The optional auto shutdown feature helps to prevent fuel wastage, as well as reduce noise levels, exhaust emissions and NOx levels of the ZW370-6 wheel loader.

Remote monitoring

Global e-Service allows ZW370-6 owners to monitor their Hitachi machines remotely via Owner's Site (24/7 online access) and ConSite (an automatic monthly

report). These help to maximise efficiency, minimise downtime and improve overall performance.

Easy operation

A sensor has been added to the torque converter output shafts for more accurate and smooth transmission control. This makes it easier to change gears and results in a more comfortable operation. The traction control system prevents slippage during digging and this helps to reduce tyre wear and enhances fuel efficiency.



The LCD monitor shows the machine's status and settings.



The new engine helps to reduce fuel costs and maintenance.



The SCR system reduces emissions and noise levels.

REDUCING THE TOTAL COST OF OWNERSHIP



Hitachi has created the Support Chain after-sales programme to ensure optimum efficiency, as well as minimal downtime, reduced running costs and high resale values.

Global e-Service

Hitachi has developed two remote monitoring systems as part of its Global e-Service online application. Owner's Site and ConSite are an integral part of the wheel loader, which sends operational data daily via GMS to www.globaleservice.com. This allows immediate access to the Owner's Site, and the vital information that is required for support on job sites.

Comparing the ratio of operating and non-operating hours helps to enhance efficiency. Effective management of maintenance programs helps to maximise availability. Running costs

can also be managed by analysing the fuel consumption. The location and movements of each machine are clearly displayed for essential planning.

An automatic service report — ConSite — sends a monthly email summarising the information from Global e-Service for each machine. This includes: daily working hours and fuel consumption data; statistics on the operating mode ratio, plus a comparison for fuel consumption/efficiency, and emissions.

Technical support

Each Hitachi service technician receives full technical training. This provides technicians access to the Hitachi's global experience and knowledge available within the Hitachi quality assurance departments and design centres. Technicians combine this global expertise with the local language and culture of the customer to provide the highest level of after-sales support.



Global e-Service



Technical support



Hitachi Parts

Extended warranty and service contracts

Every new Hitachi ZW-6 model is covered by a full manufacturer's warranty. For extra protection — due to severe working conditions or to minimise equipment repair costs — Hitachi can offer a unique extended warranty and comprehensive service contracts. These can help to enhance ownership experience of each machine, reduce downtime and ensure higher resale values.

Parts

Hitachi parts are available locally via Hitachi Branch network across Australia and New Zealand.

- Hitachi Genuine Parts allow machines to work longer with lower running and maintenance costs.
- Hitachi Genuine Parts are of proven quality and come with the manufacturer's warranty.

- Hitachi rebuilt components are available from Hitachi's in-house remanufacture centre and are offered with a standard warranty.

- Parts can be ordered via Hitachi Online Parts, local branches or Hitachi's 24/7 support centre.

Whatever the choice, the renowned quality of Hitachi construction machinery is assured.



EH dump trucks



EX ultra-large excavators



ZW wheel loaders



“ We develop construction machinery that contributes to the creation of affluent and comfortable societies ”

Yuichi Tsujimoto, HCM President

BUILDING A BETTER FUTURE

Established in 1910, Hitachi, Ltd. was built upon a founding philosophy of making a positive contribution to society through technology. This is still the inspiration behind the Hitachi group's reliable solutions that answer today's challenges and help to create a better world.

Hitachi, Ltd. is now one of the world's largest corporations, with a vast range of innovative products and services. These have been created to challenge convention, improve social infrastructure and contribute to a sustainable society.

Hitachi Construction Machinery Co., Ltd. (HCM) was founded in 1970 as a subsidiary of Hitachi, Ltd. and has become one of the world's largest construction equipment suppliers. A pioneer in producing hydraulic excavators, HCM also manufactures wheel loaders, rigid dump trucks, crawler cranes and special application machines at state-of-the-art facilities across the globe.

Incorporating advanced technology, Hitachi construction machinery has a reputation for the highest quality standards. Suitable for a wide range of industries, it is always

hard at work around the world – helping to create infrastructure for a safe and comfortable way of living, developing natural resources and supporting disaster relief efforts.

Hitachi ZW wheel loaders are renowned for being reliable, durable and versatile – capable of delivering the highest levels of productivity under the most challenging of conditions. They are designed to provide owners with a reduced total cost of ownership, and operators with the ultimate level of comfort and safety.



Mini excavators

SPECIFICATIONS

ENGINE

Model	Isuzu 6WG1
Type	4-cycle water-cooled, direct injection
Aspiration	Turbocharger and intercooled
Aftertreatment	DOC and SCR system
No. of cylinders	6
Maximum power	
ISO14396	290 kW (389 hp) at 1 800 min ⁻¹ (rpm)
ISO 9249, net	288 kW (386 hp) at 1 800 min ⁻¹ (rpm)
Rated power	
ISO14396	290 kW (389 hp) at 1 800 min ⁻¹ (rpm)
ISO 9249, net	288 kW (386 hp) at 1 800 min ⁻¹ (rpm)
Maximum torque	1 940 Nm at 1 350 min ⁻¹ (rpm)
Bore and stroke	147 mm X 154 mm
Piston displacement	15.68 L
Batteries	2 x 12 V
Air cleaner	Two element dry type with restriction indicator
Emission	Complies with EU stage IV and US EPA Tier 4 Final

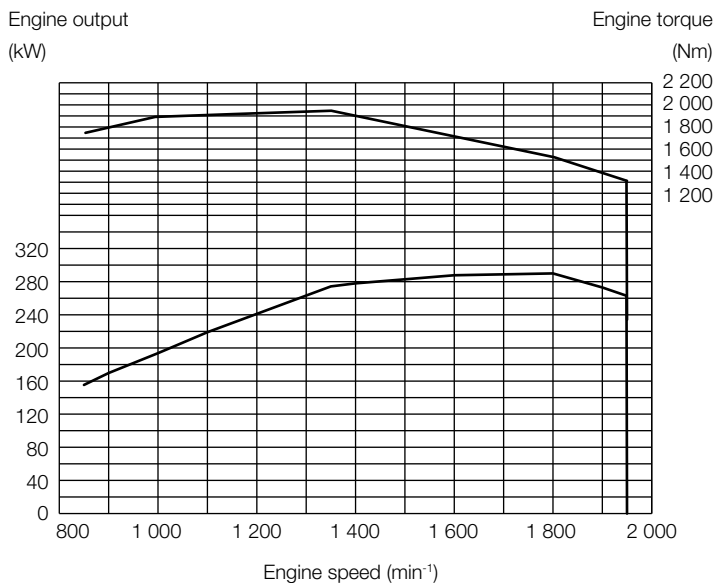

POWER TRAIN

Transmission	Torque converter, planetary gear type powershift with computer-controlled automatic shift and manual shift features included
Torque converter	Three element, single stage, single phase with lock-up clutch
Main clutch	Wet hydraulic, multi-disc type
Cooling method	Forced circulation type
Travel speed* Forward / Reverse	
1st	6.3 [6.3] / 6.8 [6.8] km/h
2nd	11.6 (12.9) [11.6 (12.9)] / 12.5 (13.9) [12.5 (13.9)] km/h
3rd	20.0 (22.7) [20.0 (22.7)] / 21.5 (24.5) [21.5 (24.5)] km/h
4th	36.0 (37.0) [36.0 (37.0)] / - [-] km/h

*With 29.5 R25 (L5) tires

(): Data at Lock-up clutch ON

[]: Date at Power mode

AXLE AND FINAL DRIVE

Drive system	Four-wheel drive system
Front & rear axle	Full-floating
Front	Fixed to the front frame
Rear	Trunnion support
Reduction and differential gear	Two stage reduction with torque proportional differential (std) / limited slip differential (optional)
Oscillation angle	Total 24° (+12°, -12°)
Final drives	Heavy-duty planetary, mounted outboard

BRAKES

Service brakes	Middle mounted fully hydraulic 4 wheel disc brake. Front & rear independent brake circuit
Parking brake	Spring applied, hydraulically released, located in front axle driveline

STEERING SYSTEM

Type	Articulated frame steering
Steering angle	Each direction 37°; total 74°
Cylinders	Double-acting piston type
No. x Bore x Stroke	2 x 90 mm x 600 mm

HYDRAULIC SYSTEM

Arm and bucket are controlled by 2 levers	
Arm controls	Four position valve ; Raise, hold, lower, float
Bucket controls with automatic bucket return-to-dig control	Three position valve ; Roll back, hold, dump
Main pump (serve as steering pump)	
.....	Variable displacement axial plunger pump
Maximum flow	340 L/min at 1 800 min ⁻¹ (rpm)
Maximum pressure ...	31.4 MPa
Fan pump	
.....	Variable displacement axial plunger pump
Maximum flow	90 L/min at 1 800 min ⁻¹ (rpm)
Maximum pressure ...	22.5 MPa
Hydraulic cylinders	
Type	Double acting type
No. x Bore x Stroke ...	Arm : 2 x 160 mm x 1 027 mm Bucket : 2 x 130 mm x 656 mm
Filters	Full-flow 15 micron return filter in reservoir
Hydraulic cycle times	
Lift arm raise	5.8 s
Lift arm lower	4.4 s
Bucket dump	1.4 s
Total	11.6 s

SERVICE REFILL CAPACITIES

Fuel tank	438 L
Engine coolant	69 L
Engine oil	52 L
Torque convertor & transmission	71 L
Front axle differential & wheel hubs	95 L
Rear axle differential & wheel hubs	95 L
Hydraulic oil tank	178 L
DEF / AdBlue® tank	57 L

DIMENSIONS & SPECIFICATIONS

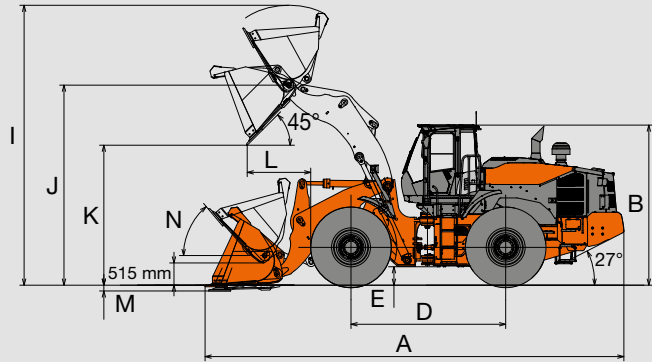
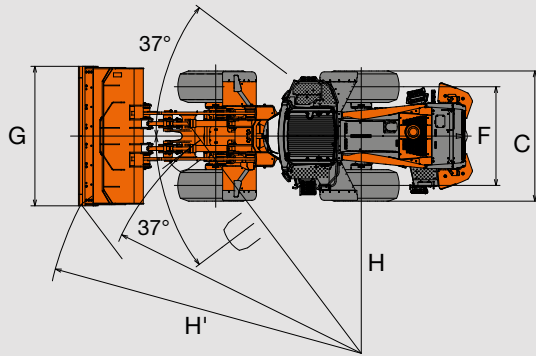

Bucket type			Standard arm			
			General purpose		Rock bucket	
			Straight edge		Straight edge	V-edge
			Bolt-on cutting edge	Bolt-on cutting edge	Bolt-on teeth	Bolt-on teeth
Bucket capacity	ISO heaped	m ³	5.6	6.2	4.8	5.0
	ISO struck	m ³	4.9	5.4	4.1	4.3
A Overall length		mm	9 715	9 805	9 795	9 975
B Overall height		mm			3 810	
C Width over tires		mm			3 230	
D Wheel base		mm			3 600	
E Ground clearance		mm			435	
F Tread		mm			2 440	
G Bucket width		mm	3 510	3 510	3 465	3 465
H Turning radius (centerline of outside tire)		mm			6 605	
H' Loader clearance radius, bucket in carry position		mm	7 850	7 875	7 880	7 885
I Overall operating height		mm	6 605	6 660	6 490	6 490
J Height to bucket hinge pin, fully raised		mm			4 695	
K Dumping clearance 45 degree, full height		mm	3 300	3 235	3 220	3 090
L Reach, 45 degree dump, full height		mm	1 465	1 530	1 505	1 625
M Digging depth (horizontal digging angle)		mm	135	135	165	165
N Max. roll back at carry position		deg			48	
Static tipping load *	Straight	kg	25 360	25 170	26 280	25 980
	Full 37 degree turn	kg	21 690	21 520	22 480	22 220
Breakout force		kgf	22 160	20 860	24 810	21 280
		kN	217	205	243	209
Operating weight*		kg	35 490	35 620	35 200	35 330
Bucket tilt-back angle at ground level		deg			39	

Note: All dimensions, weight and performance data based on ISO 6746-1:1987, ISO 7131:2009 and ISO 7546:1983

: Static tipping load and operating weight marked with include 29.5R25(L5) tires (No ballast) with lubricants, full fuel tank and operator.

Machine stability and operating weight depend on counterweight, tire size and other attachments.

WEIGHT CHANGE

Option item	Operating weight (kg)	Tipping load (kg)		Overall width (mm) (outside tire)	Overall height (mm)	Overall length (mm)	
		Straight	Full turn				
Tire	29.5R25(L3)	- 1 380	- 970	- 830	+ 15	- 40	+ 30
	29.5R25(L5)	± 0	± 0	± 0	± 0	± 0	± 0

BUCKET SELECTION GUIDE

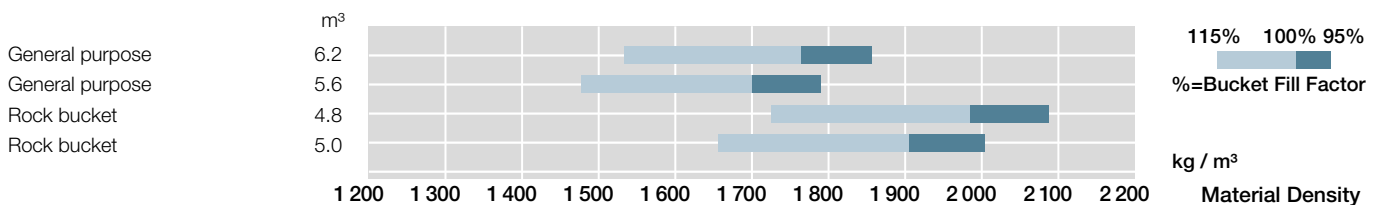

EQUIPMENT

● Standard equipment

○ Optional equipment

OPERATOR'S STATION	
Ashtray, cigar lighter	●
Auto control air conditioner*	
with double intake filter	●
Bluetooth® integrated FM/AM radio, hands free calling	●
Coat hook	●
Front/Rear defroster	●
Glove compartment	●
Rear view camera & monitor	●
Rear view mirrors	
Inside (2)	●
Outside (2)	○
Outside (Heated, 2)	●
Retractable seat belt, 50mm	●
ROPS (ISO3471), FOPS (ISO3449) : multi-plane isolation mounted for noise, vibration reduction	●
Rubber floor mat	●
Seat	
Air suspension seat with headrest and heater: fabric, high back, adjustable for damper, inclination of the seat, seat depth, weight-height, fore-aft position, reclining angle, armrest angle, headrest height and angle, lumbar support	●
Steering system	
Joystick steering (with wheel steering)	●
Storage	
Cup holder	●
Digital audio player holder	●
Document holder	●
Hot & cool box	●
Seatback pocket	●
Sun visor	●
Tinted safety glass	
Front windshield: laminated	●
Others: tempered	●
Windshield washers for front and rear	●
Windshield wipers for front and rear	●

ELECTRICAL SYSTEM	
Backup alarm	●
Batteries	
Standard batteries (147AH-930A)	○
Large capacity batteries (185AH-1170A)	●
Battery disconnect switch	●
12V power outlet	○

LIGHTS	
Bracket and switch for rotating beacon	●
Brake & LED tail lights	●
Clearance lights	●
Headlights	●
Turn signals with hazard switch	●
Work lights	
LED Front light on cab (2)	●
LED Rear lights on rear grille side cover (2)	●
Additional LED front lights on cab (2)	●
LED rear lights on cab (2)	●

POWER TRAIN	
Automatic transmission with load sensing system	●
Axle oil cooler	●
Clutch cut position switch	●
Differential	
TPD (Torque Proportioning Differential, front and rear)	●
LSD (Limited Slip Differential, front and rear)	○
DSS (Down Shift Switch)	●
Forward/Reverse selector switch	●
Lock-up clutch (torque converter)	●
Power mode switch	●
Quick power switch	●
Traction control system	●
Travel mode selector (Auto1-Auto2)	●

ENGINE	
Air filter double elements	●
Automatic reversible cooling fan with heat sensing	●
Cartridge-type engine oil filter	●
Oil mist separator (blow-by gas)	●
Cartridge-type fuel pre-filter	●
Cartridge-type fuel main filter	●
Cartridge-type water separator filter	●
Coolant reservoir sight gauge	●
DEF/AdBlue® tank inlet strainer and extension filler	●
DEF/AdBlue® tank with ISO magnet adapter	●
Engine auto shut-down control system	●
Engine oil remote drain	●
Pre-cleaner (Sy-Klone)	●
Radiator (standard fin pitch radiator)	●

Standard and optional equipment may vary by country, so please consult your Hitachi dealer for details.

* Contains fluorinated greenhouse gases, Refrigerant type : HFC-134a, GWP : 1 430, Amount : 1.00 kg, CO2e : 1.43 ton.



MONITORING SYSTEM

Gauge: coolant temperature, fuel	●
Indicator lights : clearance lights, control lever lock, fuel level, high beam, parking brake, preheat, turn signals, work lights	●
Indicator on multifunction monitor : air conditioner display, auto shut-down indicator, clock, clutch cut off indicator, Aftertreatment Device indicator, DEF level gauge, dual lift arm auto leveler indicator, ECO indicator, fan reverse indicator, F-N-R/shift position indicator, forward/reverse selector switch indicator, hold display, hour meter, joystick steering indicator (optional), odometer, power mode indicator, ride control indicator, seat belt indicator, speedometer, tachometer, transmission auto-shifting indicator, transmission oil temperature, auto brake indicator, traction control indicator.	●
Warning lights : air filter restriction, brake oil low pressure, communication system error, discharge warning, engine oil low pressure, engine warning, hydraulic oil level, low steering oil pressure, overheat, transmission warning	●

BRAKE SYSTEM

Front & rear independent brake circuit	●
Middle mounted fully hydraulic 4 wheel wet disc	●
Spring-applied/Hydraulic-released parking brake	●

HYDRAULIC SYSTEM

Bucket auto leveler (Automatic return to dig control)	●
Control lever	
for 2 spools control valve	
Multifunction lever (MF lever)	●
	
for 3 spools control valve	
MF lever & AUX lever for 3rd function	●
	
Control lever lock switch	●
Dual lift arm auto leveler	●
Hydraulic filters	●
Lift arm float system	●
Ride control system (OFF-AUTO type)	●

TIRES

29.5R25(L3)	○
29.5R25(L5)	●

MISCELLANEOUS

Articulation lock bar	●
Belly guard (Bolt on type)	
Front	●
Rear	●
Bucket cylinder guard	●
Counterweight, built-in	●
Drawbar with locking plate	●
Emergency steering	●
Fenders	
for 29.5R25	
Front & full covered rear fenders with mud flaps	●
Global e-Service	●
Lift arm	
Standard lift arm	●
Lift & tie down hooks	●
On board information controller	●
Pilfer proof	
Battery cover with locking bracket	●
Lockable engine cover	●
Lockable fuel refilling cap	●
Standard tool kit	●

Prior to operating this machine, including satellite communication system, in a country other than a country of its intended use, it may be necessary to make modifications to it so that it complies with the local regulatory standards (including safety standards) and legal requirements of that particular country. Please do not export or operate this machine outside the country of its intended use until such compliance has been confirmed. Please contact authorized dealer in case of questions about compliance.

CablePrice Pty Ltd

www.cableprice.co.nz

Hitachi Construction Machinery Australia

www.hitachicm.com.au

These specifications are subject to change without notice.

Illustrations and photos show the standard models, and may or may not include optional equipment, accessories, and all standard equipment with some differences in color and features. Before use, read and understand the Operator's Manual for proper operation.

KL-EN218AU